

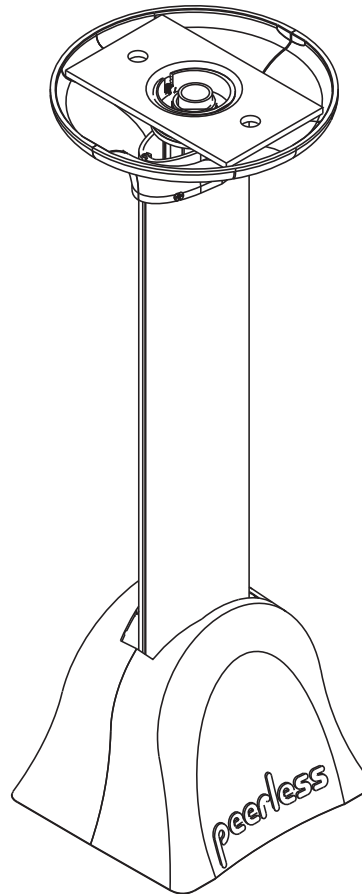

Installation and Assembly: Ceiling mount for LCD screens up to 29"

Models: LCC18-C, LCC18-CS, LCC36-C, LCC36-CS

Patent Pending



**Horizontal
Position**

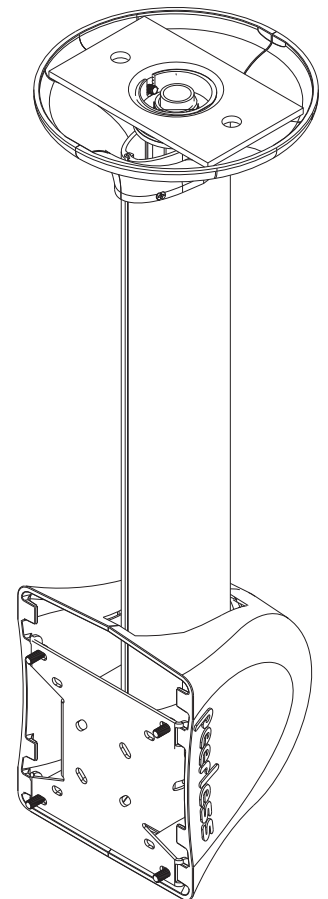

**Vertical
Position**

Features:

- Comes in two adjustable height ranges (in 1" increments): 18"-30" and 36"-48"
- -5° to +20° adjustable tilt
- Screen can be mounted in standard position or face-down
- Portrait or landscape orientation
- Ceiling plate included
- Hardware included for wood or concrete installations
- Snap-together cover provides sleek aesthetics and cord management
- Theft resistant security fasteners included
- VESA® 75/100 mm compliant (Non-VESA adapter offered separately)
- Comes in black and silver
- 360° swivel action



Max UL Load Capacity: 40 lb (18.1 kg)

Note: Read entire instruction sheet before you start installation and assembly.

▲ WARNING

- Do not begin to install your Peerless product until you have read and understood the instructions and warnings contained in this Installation Sheet. If you have any questions regarding any of the instructions or warnings, please call Peerless customer care at 1-800-729-0307.
- This product should only be installed by a qualified professional.
- Make sure that the ceiling will safely support the combined load of the equipment and all attached hardware and components.
- Never exceed the Maximum UL Load Capacity of 40 lb (18.1 kg).
- If mounting to wood ceiling joists, make sure that mounting screws are anchored into the center of the joists. Use of an "edge to edge" stud finder is highly recommended.
- Always use an assistant or mechanical lifting equipment to safely lift and position equipment.
- Tighten screws firmly, but do not overtighten. Overtightening can damage the items, greatly reducing their holding power.

Accessories

- Lightweight Adjustable Suspended Ceiling Kit (CMJ 500)
- Lightweight Suspended Ceiling Kit (CMJ 455)
- Accessory Pack for CMJ 455 (ACC 455)*
- Lightweight Cathedral Ceiling Plate (ACC 912)*
- Unistrut or Structural Ceiling Plates (CMJ 300, CMJ 310)*
- Anti-Vibration Ceiling Plates (ACC 845)*
- I-Beam Clamps (ACC 558, ACC 559)
- Truss Ceiling Adapter (ACC 557)*
- Unistrut Adapter (ACC 550)
- 3/4" Pipe Reducer (ACC 913)*
- Fixed Length 1 1/2" Extension Columns (EXT models)
- Adjustable Length 1 1/2" Extension Columns (ADJ models)
- Extension Column Stabilizer Kit (ACC 050)*
- Extension Column Connector (ACC 109)
- 1/2" Threaded Rod (ACC 820)*
- Threaded Rod Adapter (ACC 810)*
- Non-VESA® Adapter Plates (LC models)*

*** not evaluated by UL**

Tools Needed for Assembly

- stud finder ("edge to edge" stud finder is recommended)
- phillips screwdriver
- drill with 1/4", 3/8", 5/32", and #46 drill bits
- handsaw
- carpenter's knife

Table of Contents

Parts List	3
Installation to Wood Joist Finished Ceilings, Exposed Wood Joists, or Wood Beam Ceilings	4
Installation to Concrete Ceilings	5
Installing Reducer	6
Flush Mount Installation	7
Installation to Threaded Rod	7
Installation to Extension Column	8
Installation to Lightweight Suspended Ceiling Plate	9
Attaching Tilt Bracket to LCD Screen	10
Installation of Plasma in the Vertical Position	11
Installation of Plasma in the Horizontal Position	12
Installation of Vertical Covers	13
Installation of Top Covers	13
Installation of Tilt Covers in the Vertical Position	14
Installation of Tilt Covers in the Horizontal Position	14

Parts List

Description	Qty.	LCC 18-C Part #	LCC 18-CS Part #	LCC 36-C Part #	LCC 36-CS Part #
A tube assembly	1	055-1520	055-4520	055-1521	055-4521
B ceiling plate	1	580-1042	580-4042	580-1042	580-4042
C tilt bracket	1	055-1551	055-4551	055-1551	055-4551
D reducer	1	580-1009	580-4009	580-1009	580-4009
E #14 x 2.5" wood screw	2	5S1-015-C03	5S1-015-C04	5S1-015-C03	5S1-015-C04
F M5 x 12 mm socket pin screw	4	520-1064	520-2064	520-1064	520-2064
G 4 mm security allen wrench	1	560-9646	560-9646	560-9646	560-9646
H Alligator® concrete anchor	2	590-0097	590-0097	590-0097	590-0097
I 10-32 x 3/8" socket set screw	1	520-1127	500-2018	520-1127	500-2018
J hex wrench	1	560-1034	560-1034	560-1034	560-1034
K M4 x 10 mm socket pin screw	4	520-1060	520-2060	520-1060	520-2060
L M4 x 12 mm serrated washer head socket pin screw	4	510-1079	510-2079	510-1079	510-2079
M M4 x 20 mm socket pin screw	4	520-1061	520-2163	520-1061	520-2163
N #10-32 x 3/16" slotted set screw	1	520-1187	520-2187	520-1187	520-2187
O retaining spacer	4	590-5005	590-5003	590-5005	590-5003
P M5 x 10 mm socket pin F-type screw	1	520-1164	520-2031	520-1164	520-2031
Q vertical cover	2	590-1183	590-4183	590-1184	590-4184
R top cover	2	590-1185	590-4185	590-1185	590-4185
S tilting cover	2	590-1186	590-4186	590-1186	590-4186
T #4-24 x 3/8" flat head phillips screw	3	560-1715	560-4715	560-1715	560-4715
U cable tie	3	590-1168	590-1168	590-1168	590-1168
V super glue	1	600-0017	600-0017	600-0017	600-0017
W alcohol pad (not shown)	1	600-0018	600-0018	600-0018	600-0018

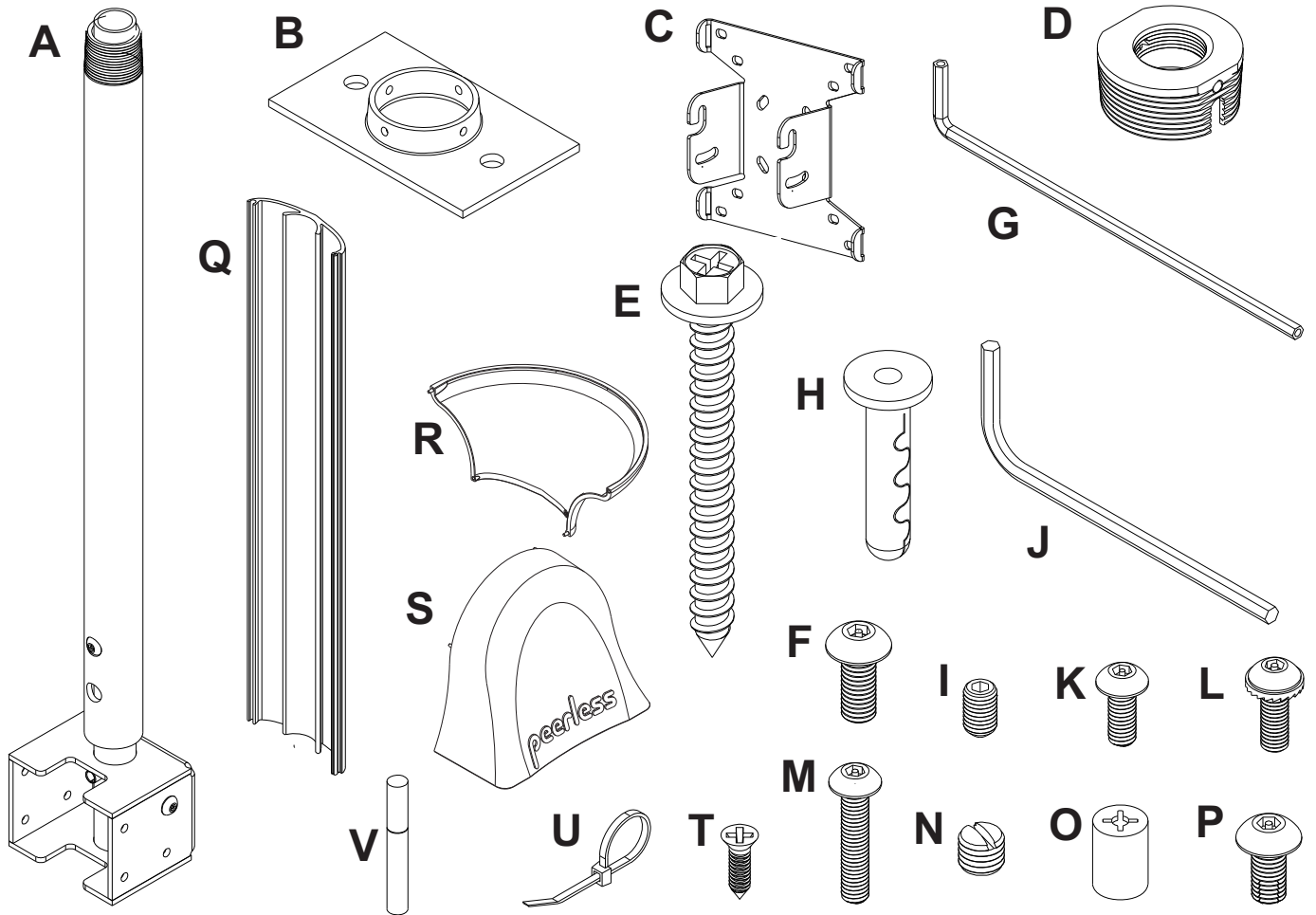

Installation to Wood Joist Finished Ceilings, Exposed Wood Joists, or Wood Beam Ceilings

- 1 Drill two 5/32" (4 mm) dia. holes to a minimum depth of 2.5" (64 mm). Attach ceiling plate (B) with two #14 x 2.5" (6 mm x 65 mm) wood screws (E) as shown using 3/8" (10 mm) socket wrench. Tighten wood screws (E) so ceiling plate (B) is firmly attached.

⚠ WARNING

- Tighten wood screws so that ceiling plate is firmly attached, but do not overtighten. Overtightening can damage the screws, greatly reducing their holding power.
- Never tighten in excess of 80 in • lb (9 N.M.).
- Make sure that mounting screws are anchored into the center of the joist. The use of an "edge to edge" stud finder is highly recommended.

Skip to step 2 on page 6.

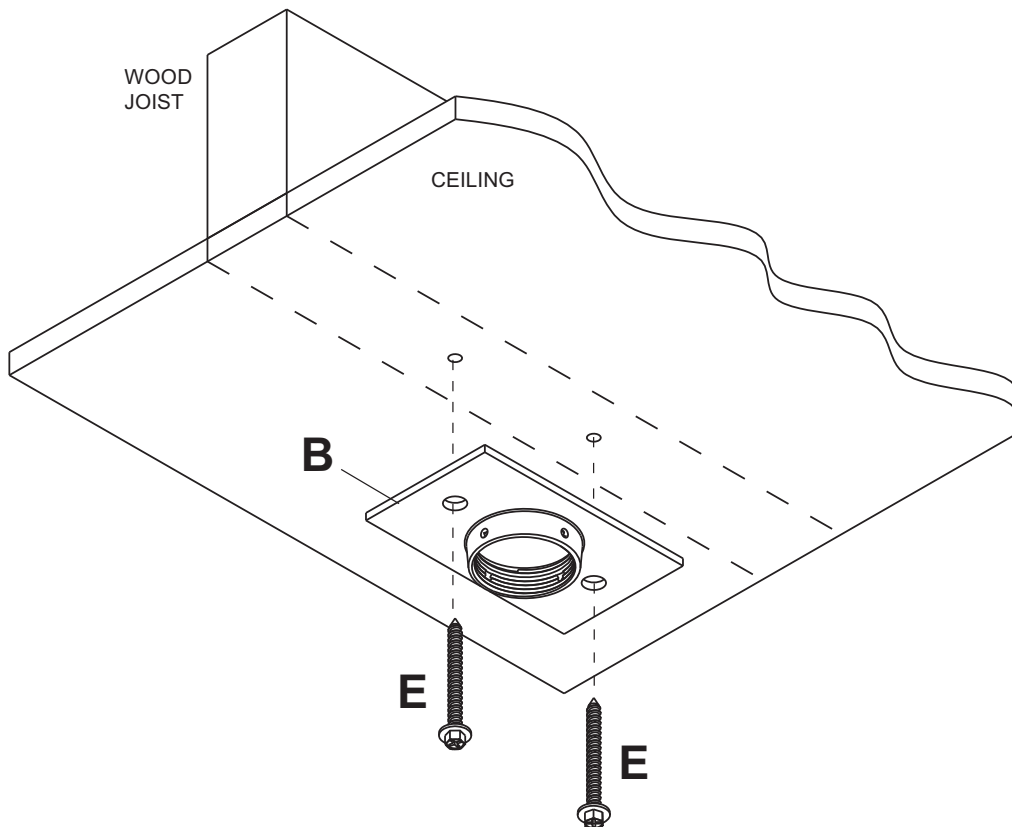

Installation to Concrete Ceilings

- 1 Drill two 1/4" (6 mm) dia. holes to a minimum depth of 2.5" (64 mm). Attach ceiling plate (B) using two concrete anchors (H) and #14 x 2.5" wood screws (E) as shown in **Illustration A** and 1, 2, and 3 (below). Tighten all fasteners.

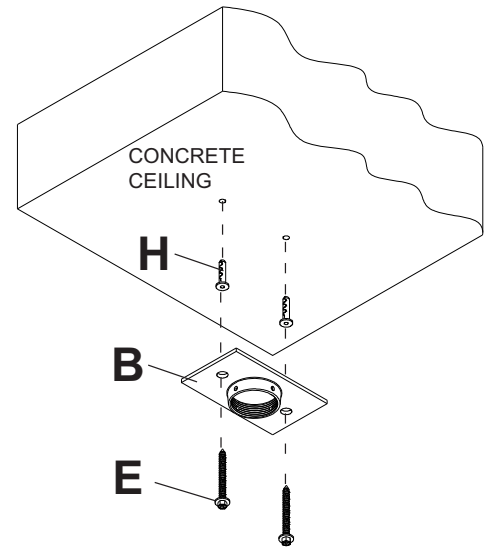

Illustration A

⚠ WARNING

- Tighten wood screws firmly, but do not overtighten. Overtightening can damage the bolt, greatly reducing its holding power.
- Never tighten in excess of 80 in • lb (9 N.M.).

⚠ WARNING

- Concrete anchors are **not** intended for attachment to concrete wall covered with a layer of plaster, drywall, or other finishing material. If mounting to concrete wall covered with plaster/drywall is unavoidable, plaster/drywall (up to 5/8" thick) must be counterbored as shown below. If plaster/drywall is thicker than 5/8", custom fasteners must be supplied by installer (not evaluated by UL).

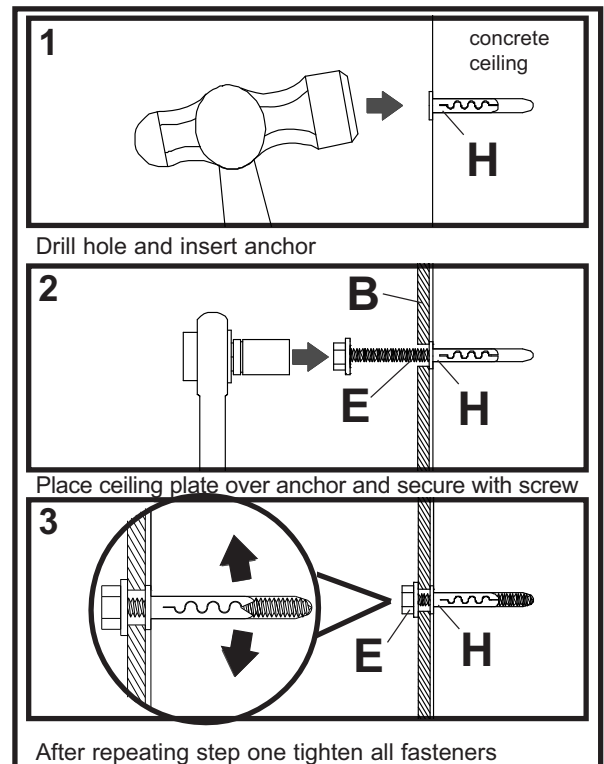
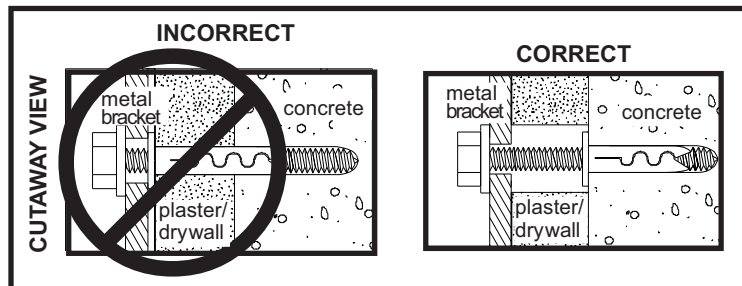

Installing Reducer

- 2** Thread reducer (D) onto tube assembly (A) until tight. Insert set screw (I) into reducer as shown in figure 2-1. Tighten screw using hex wrench (J). **Note:** Set screw (I) is used to jam against the threads of tube assembly to prevent any excess movement.

To adjust height of tube assembly (A), remove socket pin screw and two lock washers using 4 mm security allen wrench (G) and adjust to desired height as shown in figure 2-2.

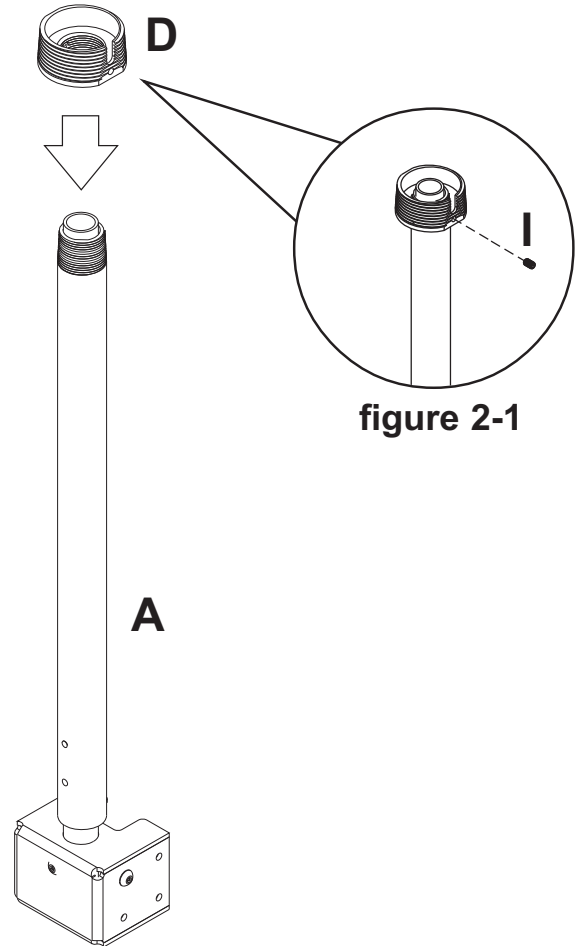

figure 2-1

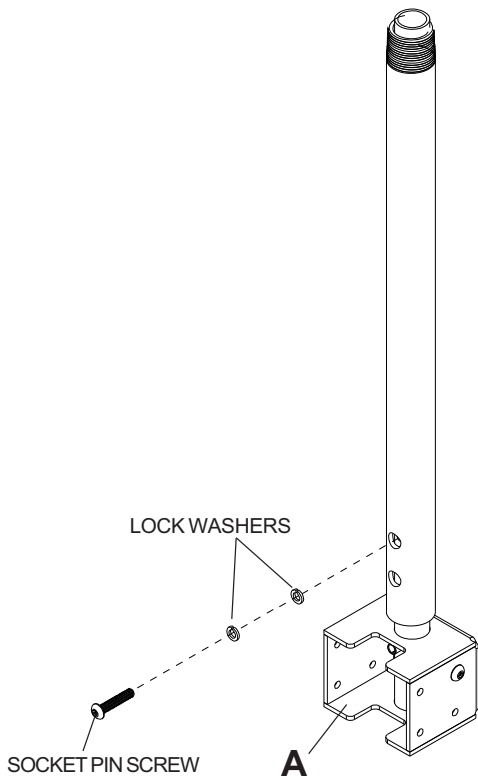
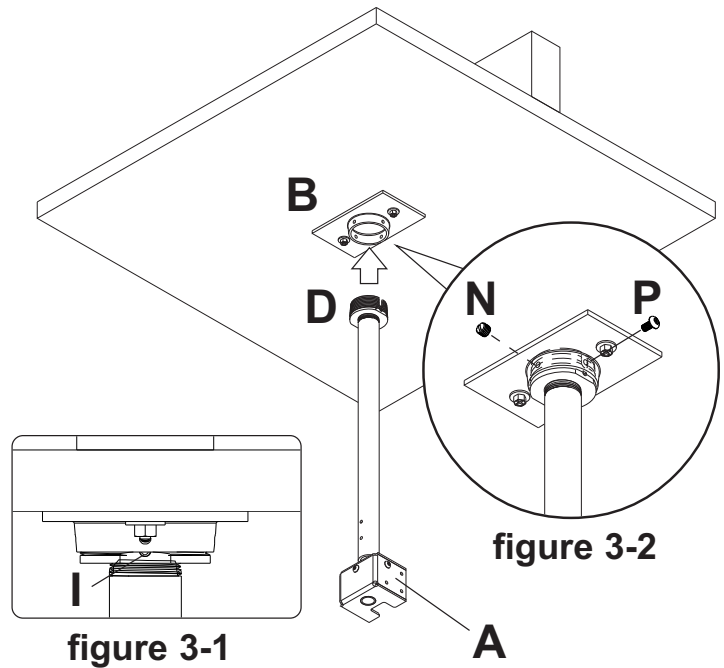

figure 2-2

Flush Mount Installation

- 3** Screw reducer (D) into ceiling plate (B) until notch in reducer is aligned with one of the four holes in ceiling plate and set screw (I) is at least partially covered by ceiling plate as shown in figure 3-1. Secure reducer with one M5 x 10 mm F-type socket pin screw (P) using security allen wrench (G) as shown in figure 3-2. **Note:** Slotted set screw (N) is used to jam against the threads of the reducer to prevent any excess movement of the tube assembly (A). Do not overtighten screw; overtightening screw will damage threads making it difficult to separate the products.

Skip to step 4 on page 10.



Installation to Threaded Rod

Accessory ACC 810 (not evaluated by UL), threaded rod adapter, is required.

- 3** Screw threaded rod adapter (ACC 810) into extension column connector (ACC 109). Align slot in threaded rod adapter with one of the top holes in extension column connector. Insert and tighten one #10-32 x 3/8" socket pin screw provided with extension column connector through extension column connector into slot on threaded rod adapter using 4 mm security allen wrench (G). See figure 3-3.

Align slot in reducer (D) to one of the bottom holes in extension column connector. Insert and tighten one #10-32 x 3/8" socket pin screw provided with extension column connector through extension column connector into slot in reducer. See figure 3-4.

Note: Slotted set screws provided with extension column connector are used to jam against the threads of each connecting joint to prevent any excess movement. Do not overtighten screws; overtightening screws will damage threads making it difficult to separate the products.

Skip to step 4 on page 10.

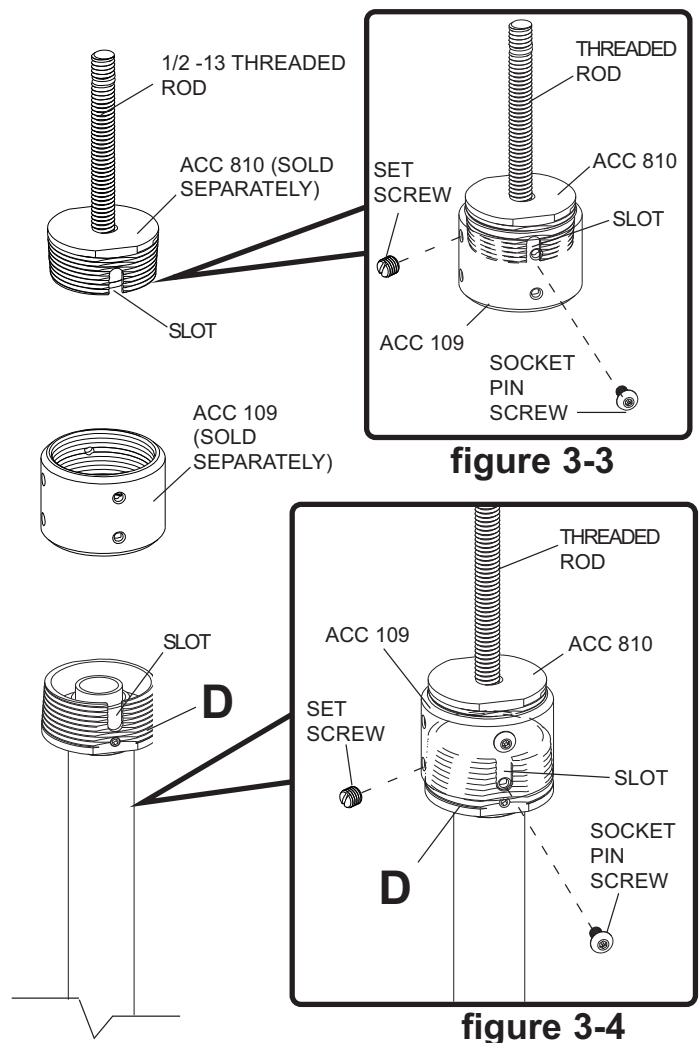

Installation to Extension Column

3 Screw extension column (**EXT or ADJ Series**) to ceiling plate (**B**). Align the notch with one of the four holes in the ceiling plate and secure extension column with a M5 x 10 mm socket pin screw (**P**) using security allen wrench (**G**). See figure 3-5.

Note: Slotted set screw (**N**) is used to jam against the threads of the reducer to prevent any excess movement of the extension column. Do not overtighten screw; overtightening screw will damage threads making it difficult to separate the products.

Screw extension column connector (**ACC 109**) to extension column. Align slot in extension column with one of the top holes in extension column connector. Insert and tighten one #10-32 x 3/8" socket pin screw provided with projector through extension column connector into slot on extension column using security allen wrench (**G**). See figure 3-6.

Screw reducer (**D**) to extension column connector. Align reducer to one of the bottom holes in extension column connector. Insert and tighten one #10-32 x 3/8" socket pin screw provided with connector through extension column connector into slot in reducer using security allen wrench (**G**). See figure 3-7.

Note: Slotted set screws provided with extension column connector are used to jam against the threads of each connecting joint to prevent any excess movement. Do not overtighten screws; overtightening screws will damage threads making it difficult to separate the products.

Skip to step 4 on page 10.

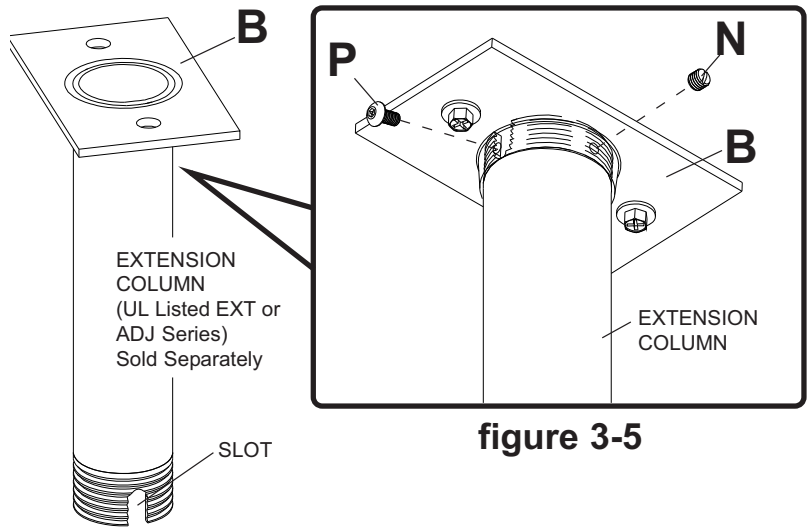

figure 3-5

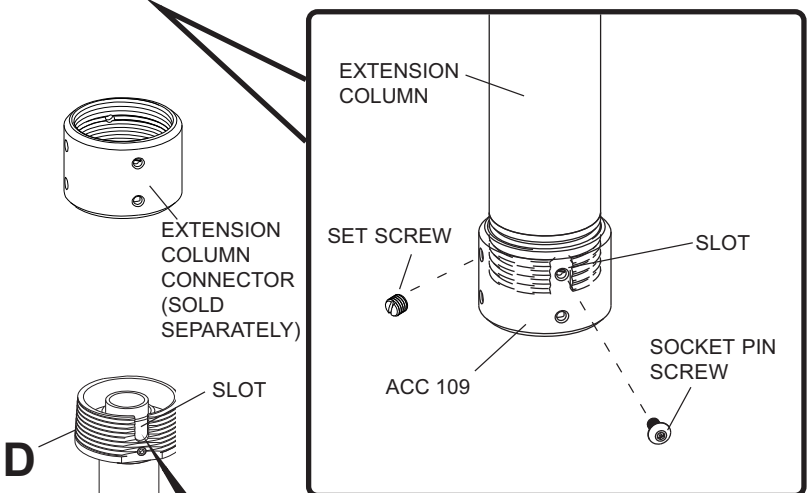

figure 3-6

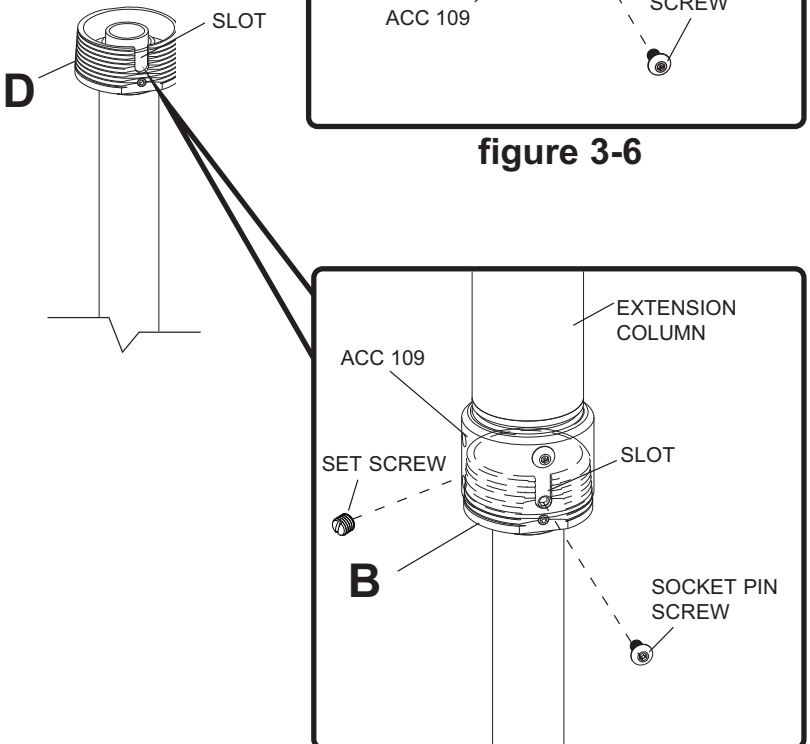
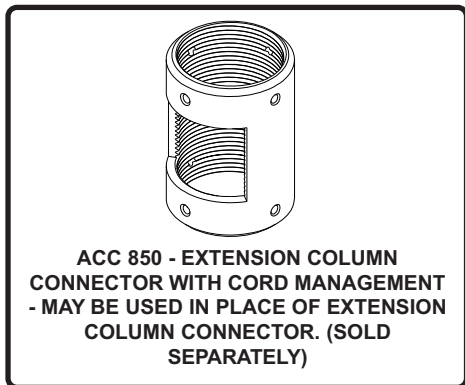

figure 3-7



Installation to Lightweight Suspended Ceiling Plate

3 Refer to instruction sheet for lightweight suspended ceiling plate (**CMJ 455**) for attachment of ceiling plate to ceiling.

Screw extension column (**EXT or ADJ Series**) to retaining collar in ceiling tray. Align the notch with one of the four holes in retaining collar and secure extension column with one M5 x 10 mm socket pin screw (**P**) using security allen wrench (**G**). See figure 3-8.

Note: Slotted set screw (**N**) is used to jam against the threads of the reducer to prevent any excess movement of the extension column. Do not overtighten screw; overtightening screw will damage threads making it difficult to separate the products.

Screw extension column connector to extension column. Align slot in extension column with one of the top holes in extension column connector. Insert and tighten one 10-32 x 3/8 socket pin screw provided with connector through extension column connector into slot on extension column using security allen wrench. See figure 3-9.

Screw reducer (**D**) to extension column connector. Align slot in reducer to one of the bottom holes in extension column connector. Insert and tighten one 10-32 x 3/8 socket pin screw provided with connector through extension column connector into slot in reducer using security allen wrench. See figure 3-10.

Note: Slotted set screws provided with extension column connector are used to jam against the threads of each connecting joint to prevent any excess movement. Do not overtighten screws; overtightening screws will damage threads making it difficult to separate the products.

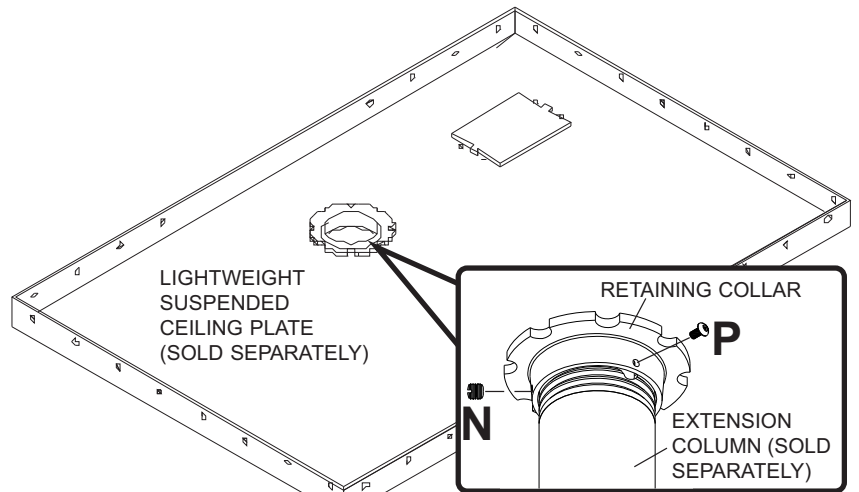
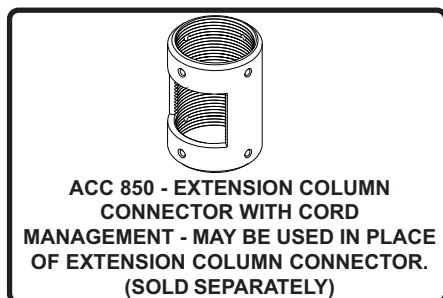

figure 3-8

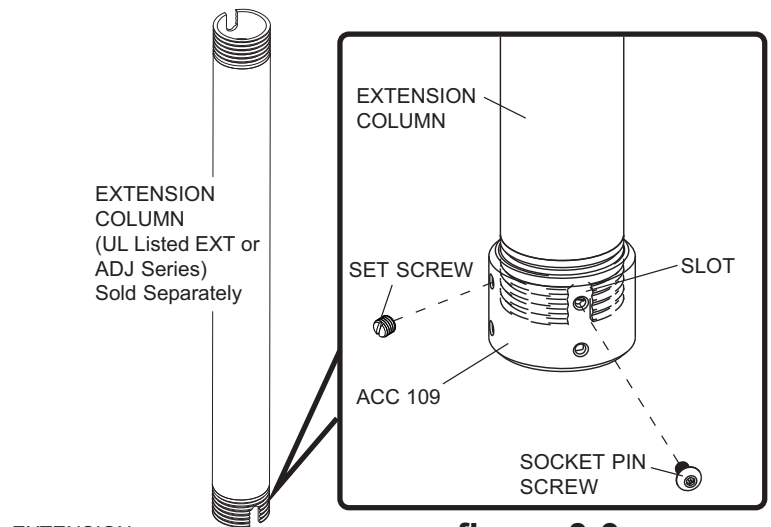

figure 3-9

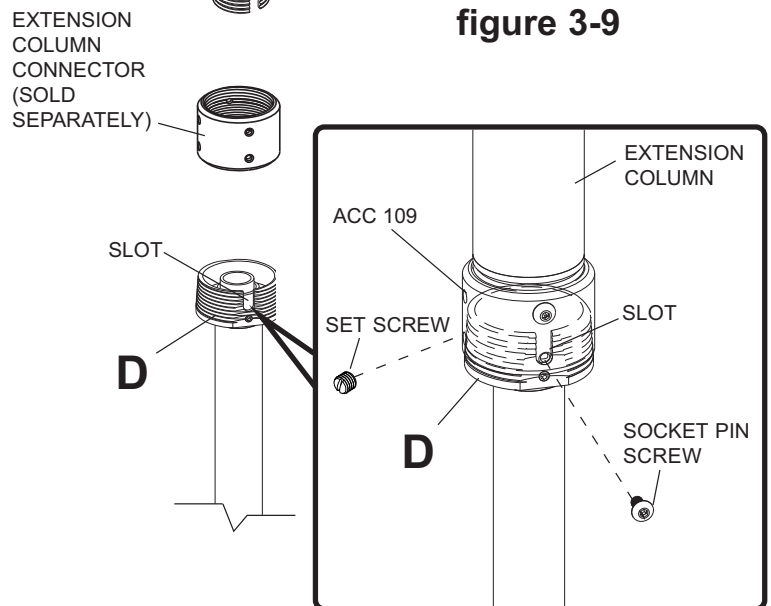

figure 3-10

Attaching Tilt Bracket to LCD Screen

4 **Note:** This product is designed to accommodate screens with VESA® compliant hole patterns. For safe mounting, please make sure that mounting screws turn at least three complete turns in the screen inserts.

FOR VESA 75 MOUNTING PATTERN:

1) Choose hole pattern indicated below. 2) Attach tilt bracket (**C**) to back of screen using four M4 x 10 mm screws (**K**) as indicated below. 3) If hole pattern is in a pocket, attach tilt bracket to back of screen using four M4 x 20 mm screws (**M**) and four retaining spacers (**O**) as indicated below. Tighten all security screws with security allen wrench (**G**).

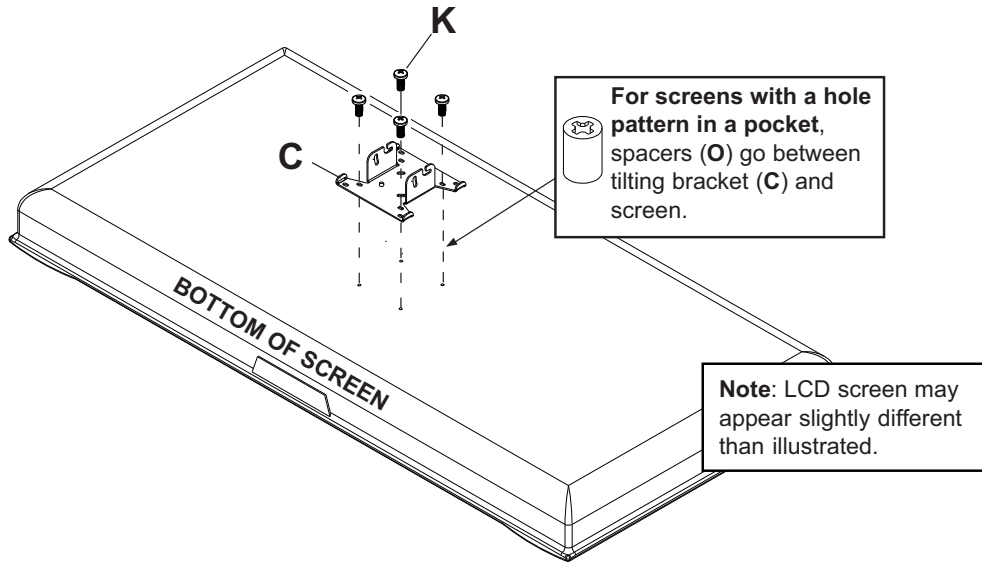

FOR VESA 100 MOUNTING PATTERN:

1) Choose hole pattern indicated below. 2) Attach tilt bracket (**C**) to back of screen using four M4 x 10 mm screws (**K**) as indicated below. Tighten all security screws with security allen wrench (**G**).

Note: If installing LCD screen model Sharp® LC-13E1U, LC-15E1U, LC-20E1U, or if you don't get three complete turns in the screen inserts, use four M4 x 12 mm screws (**L**) instead of four M4 x 10 mm screws (**K**).

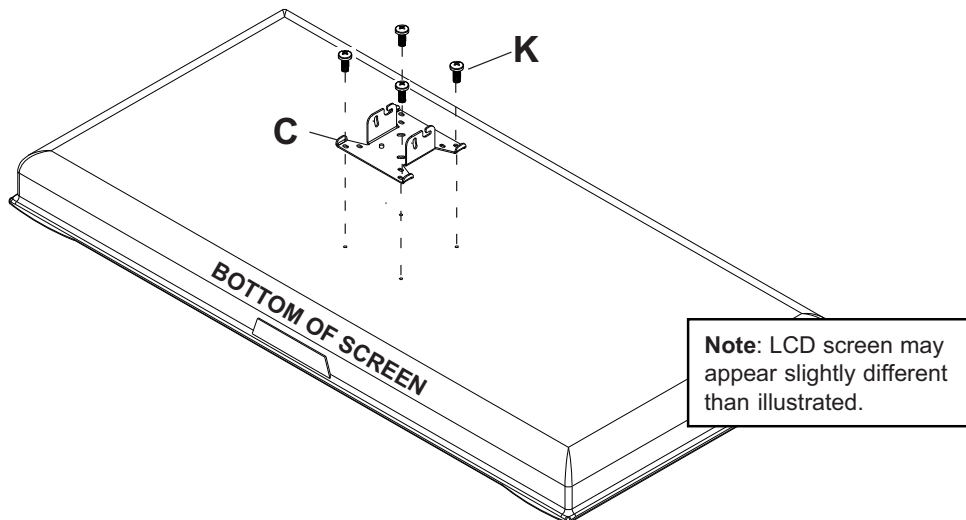

Installation of Screen in the Vertical Position

- 5** Insert two M5 x 12 mm screws (F) into column bracket of tube assembly (A) (see figure 5-1). Leave approximately 3/16" of thread exposed (see figure 5.2).

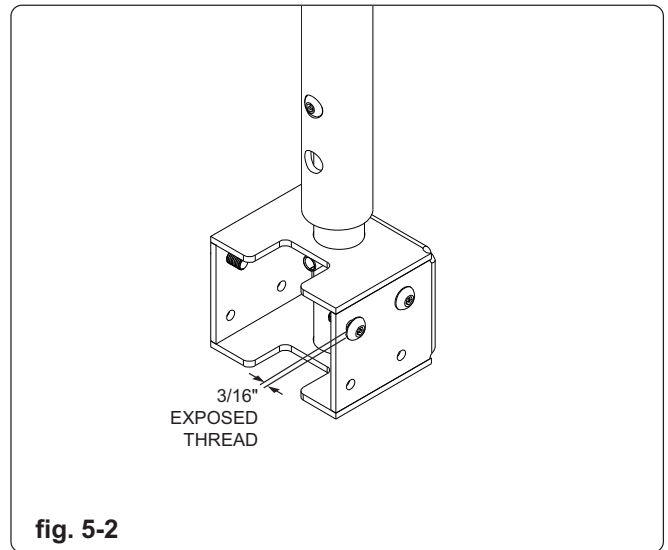
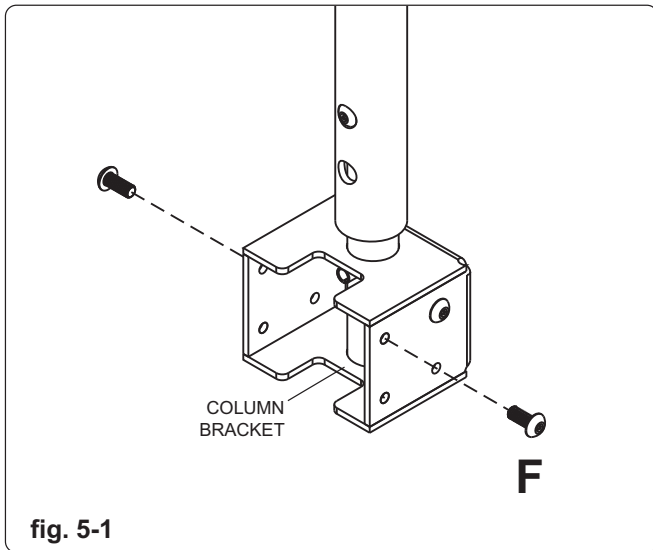

- 6** Hook tilt bracket (C) onto column bracket (see figure 6-1). Secure with two M5 screws (F) (see figure 6-2). Adjust tilt (20° forward and 5° back) and swivel to desired position. Tighten all screws using security allen wrench (G).
Note: Cable ties (U) are provided for optional cord management.

⚠ WARNING

- Always use an assistant or mechanical lifting equipment to safely lift and position the LCD screen.

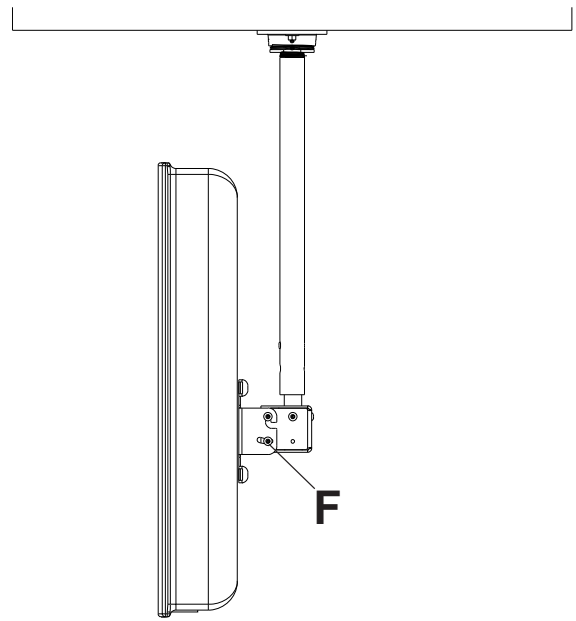
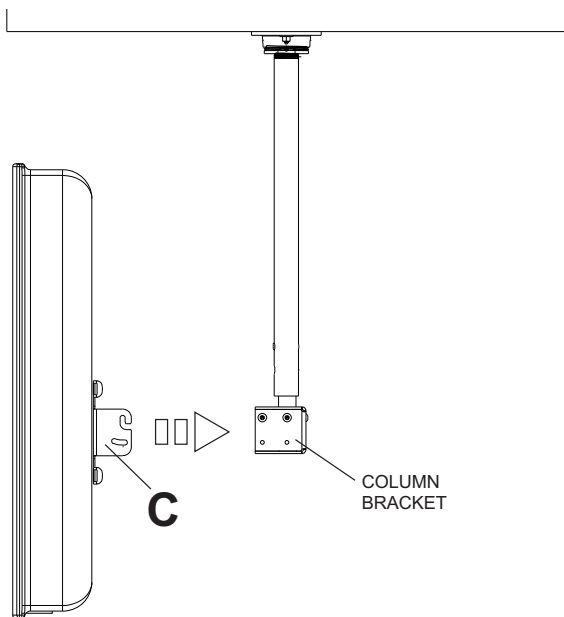

Installation of Screen in the Horizontal Position

- 5** Insert two M5 x 12 mm screws (F) into column bracket of tube assembly (A) (see figure 5-1). Leave approximately 3/16" of thread exposed (see figure 5-2).

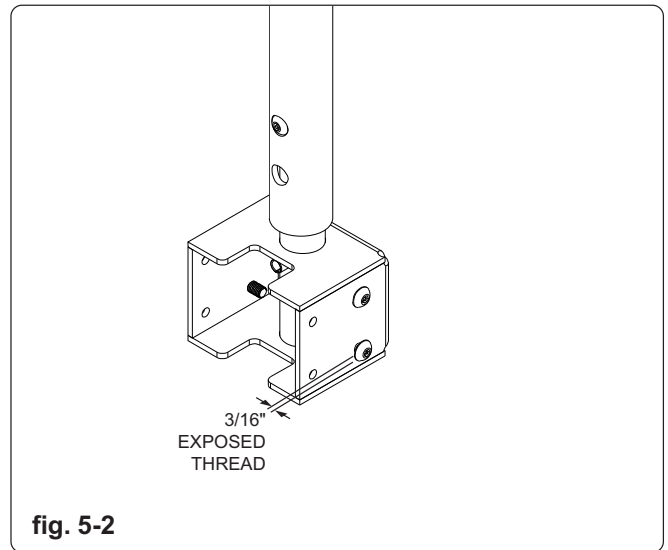
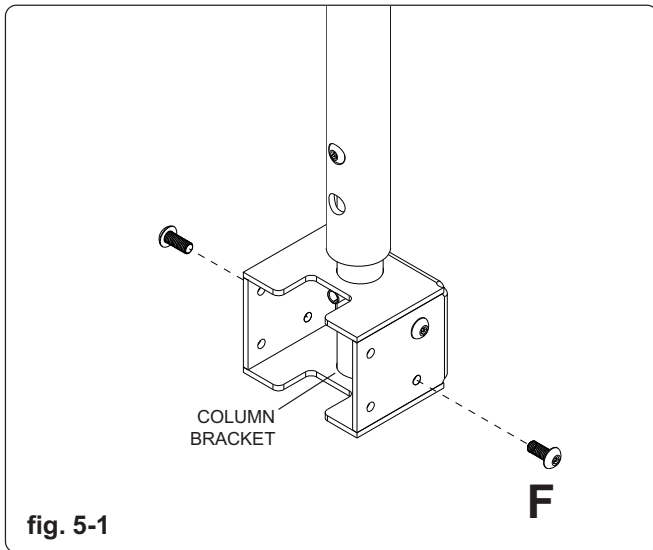

- 6** Hook tilt bracket (C) onto column bracket (see figure 6-1). Secure with two M5 screws (F) (see figure 6-2). Adjust tilt (20° forward and 5° back) and swivel to desired position. Tighten all screws using security allen wrench (G).
Note: Cable ties (U) are provided for optional cord management.

⚠ WARNING

- Always use an assistant or mechanical lifting equipment to safely lift and position the LCD screen.

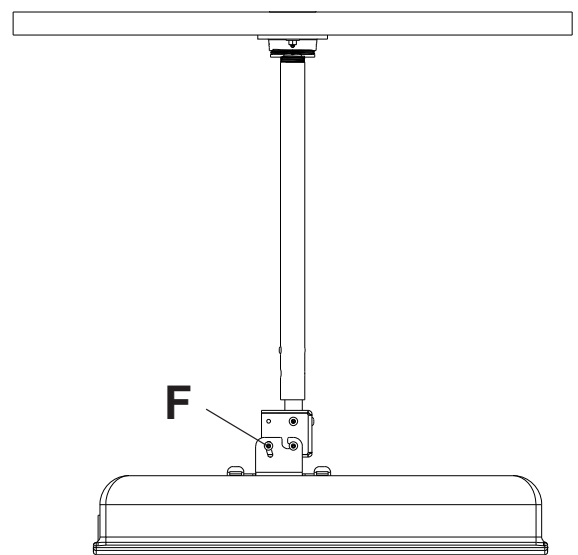
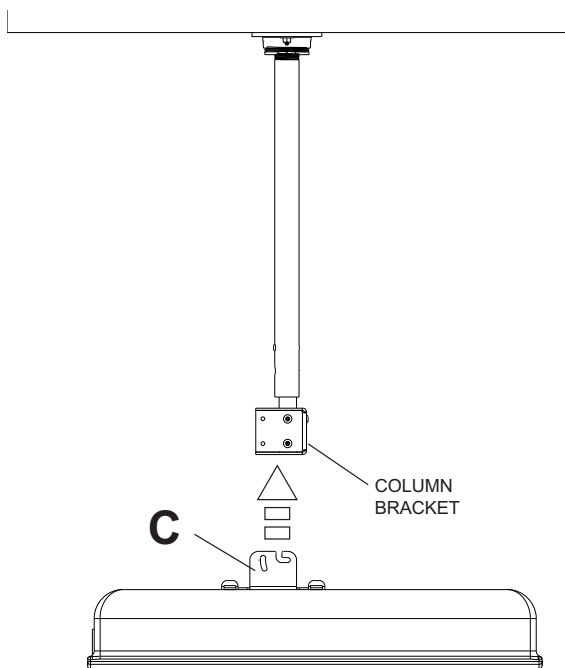
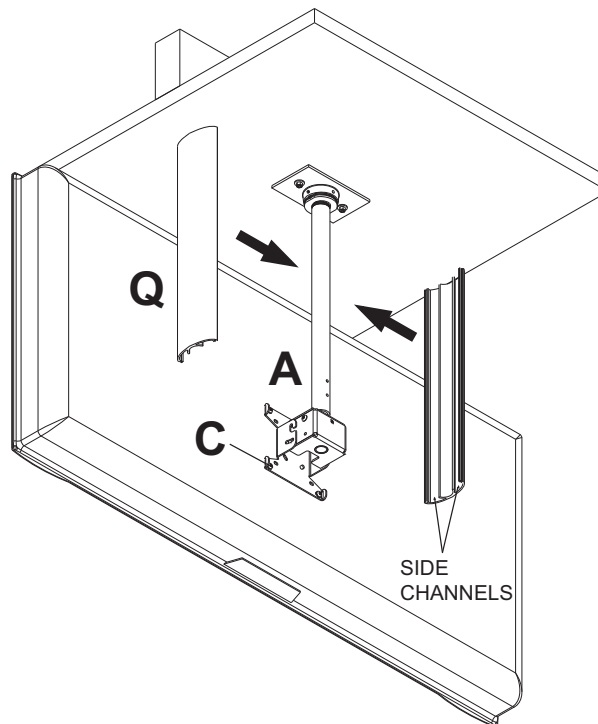

fig. 6-1

fig. 6-2

Installation of Vertical Covers

- 7** Route cords through side channels of one vertical cover (**Q**). Snap two vertical covers together on tube assembly (**A**) so that they are perpendicular to tilt bracket (**C**). If necessary, use a handsaw to cut vertical covers to match the length of tube assembly.



Installation of Top Covers

- 8** Snap two top covers (**R**) together flush with finished ceiling. Use holes in top covers to mark vertical covers (**Q**). Using a #46 (approx. .0810") drill bit, drill holes in vertical covers. (**Note:** It may be necessary to remove vertical covers before drilling holes to avoid damaging cables.) Remove top covers (**R**). Use glue (**V**) on the inside edge of one of the two top covers (**R**) so that the two sides will stick together when they are connected. Secure top covers to vertical covers using two #4-24 x 3/8" flat head phillips screws (**T**) as shown in figure 8-1.

Note: One extra flat head phillips screw (**T**) has been provided.

Note: Alcohol pad (**W**) may be used for clean up of glue.

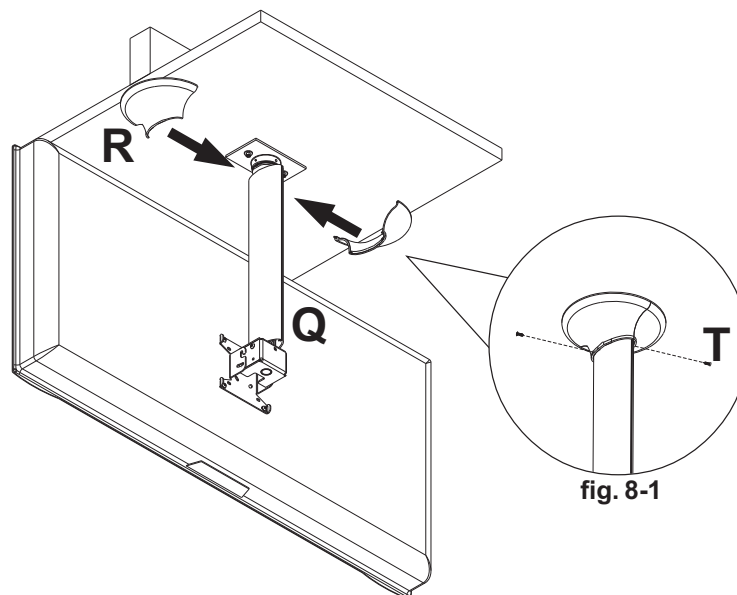

Installation of Tilt Covers in the Vertical Position

- 9** Using a carpenter's knife, cut out any sections of tilt covers (**S**) necessary to allow them to snap together over vertical covers (**Q**) as shown in figure 9-1. **Note:** Cut out sections of one tilt cover should mirror cut out sections of the other. Use glue (**V**) on the inside edge of one of the two tilting covers (**S**) so that the two sides will stick together when they are connected. Insert tabs of tilt covers into slots of tilt bracket (**C**) and snap tilt covers together.

Note: Alcohol pad (**W**) may be used for clean up of glue.

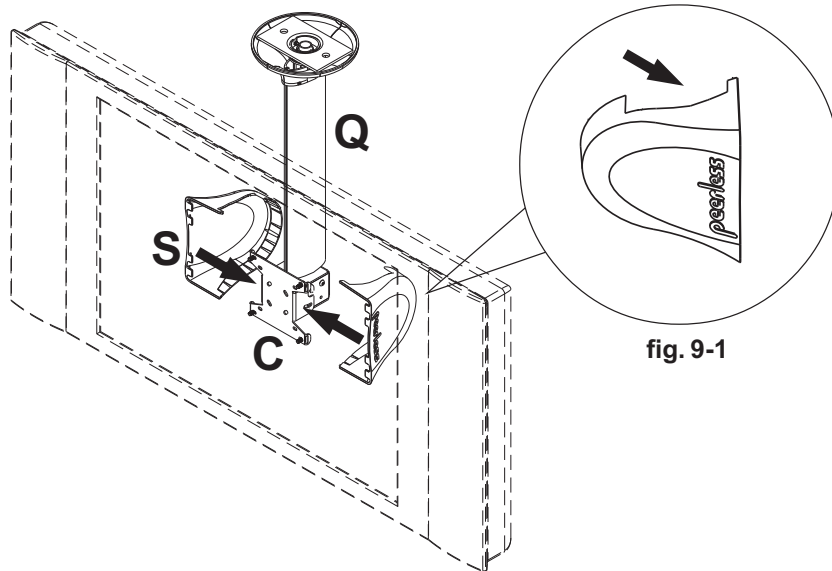

Installation of Tilt Covers in the Horizontal Position

- 9** Using a carpenter's knife, cut out any sections of tilt covers (**S**) necessary to allow them to snap together over vertical covers (**Q**) as shown in figure 9-1. **Note:** Cut out sections of one tilt cover should mirror cut out sections of the other. Use glue (**V**) on the inside edge of one of the two tilting covers (**S**) so that the two sides will stick together when they are connected. Insert tabs of tilt covers into slots of tilt bracket (**C**) and snap tilt covers together.

Note: Alcohol pad (**W**) may be used for clean up of glue.

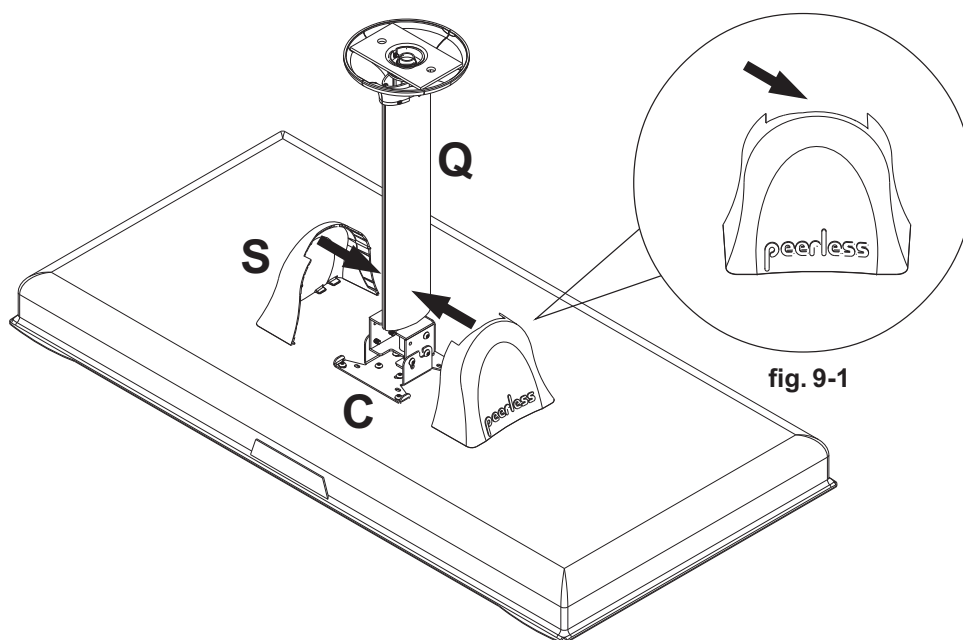



Installation and Assembly: Ceiling mount for LCD screens up to 29"

Models: LCC-18, LCC-18-S, LCC-36, LCC-36-S, LCC-36-W

Patent Pending

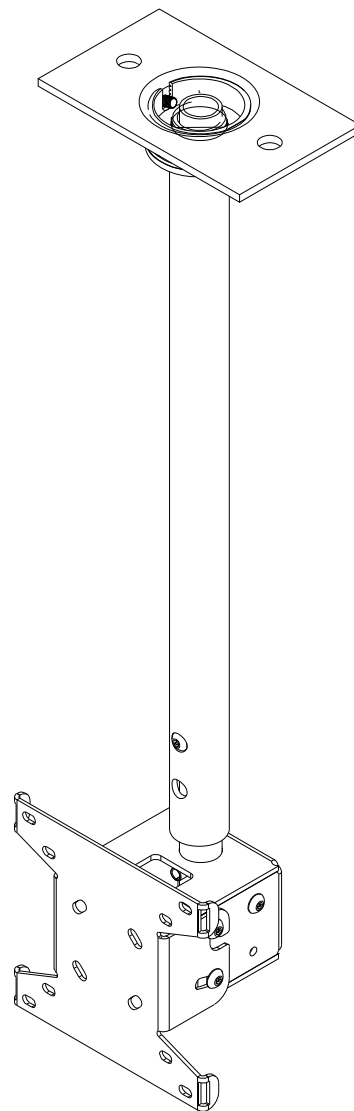

Features:

- Comes in two adjustable height ranges (in 1" increments): 18"-30" and 36"-48".
- -5° to +20° adjustable tilt.
- Screen can be mounted in standard position or face-down.
- Portrait or landscape orientation.
- Ceiling plate included.
- Hardware included for wood or concrete installations.
- Theft resistant security fasteners included.
- VESA® 75/100 mm compliant (Non-VESA adapter offered separately).
- Comes in black or silver. LCC 36-W offered in white.
- 360° swivel action.



Max UL Load Capacity: 40 lb (18.1 kg)

Note: Read entire instruction sheet before you start installation and assembly.

▲ WARNING

- Do not begin to install your Peerless product until you have read and understood the instructions and warnings contained in this Installation Sheet. If you have any questions regarding any of the instructions or warnings, please call Peerless customer service at 1-800-729-0307.
- This product should only be installed by a qualified professional.
- Make sure that the ceiling will safely support the combined load of the equipment and all attached hardware and components.
- Never exceed the Maximum UL Load Capacity. See page 1.
- If mounting to wood ceiling joists, make sure that mounting screws are anchored into the center of the joists. Use of an "edge to edge" stud finder is highly recommended.
- Always use an assistant or mechanical lifting equipment to safely lift and position equipment.
- Tighten screws firmly, but do not overtighten. Overtightening can damage the items, greatly reducing their holding power.

Accessories

- Lightweight Adjustable Suspended Ceiling Kit (CMJ 500)
- Lightweight Suspended Ceiling Kit (CMJ 455)
- Accessory Pack for CMJ 455 (ACC 455) *
- Lightweight Cathedral Ceiling Plate (ACC 912)*
- Unistrut or Structural Ceiling Plates (CMJ 300, CMJ 310)*
- Anti-Vibration Ceiling Plates (ACC 845)*
- I-Beam Clamps (ACC 558, ACC 559)
- Truss Ceiling Adapter (ACC 557)*
- Unistrut Adapter (ACC 550)
- Escutcheon Ring (ACC 640)*
- Round Ceiling Plate (ACC 570)
- Cord Wrap (ACC 852(W)(S))*
- 3/4" Pipe Reducer (ACC 913)*
- Fixed Length 1 1/2" Extension Columns (EXT models)
- Adjustable Length 1 1/2" Extension Columns (ADJ models)
- Extension Column Stabilizer Kit (ACC 050)*
- Extension Column Connector (ACC 109)
- 1/2" Threaded Rod (ACC 820)*
- Threaded Rod Adapter (ACC 810)*
- Non-VESA Adapter Plates (LC models)*

*** not evaluated by UL**

Tools Needed for Assembly

- stud finder ("edge to edge" stud finder is recommended)
- phillips screwdriver
- drill with 1/4", 3/8", and 5/32" drill bits

Table of Contents

Parts List	3
Installation to Wood Joist Finished Ceilings, Exposed Wood Joists, or Wood Beam Ceilings	4
Installation to Concrete Ceilings	5
Installing Reducer	6
Flush Mount Installation	7
Installation to Threaded Rod	7
Installation to Extension Column	8
Installation to Lightweight Suspended Ceiling Plate	9
Attaching Tilt Bracket to LCD Screen	10
Installation of Plasma in the Vertical Position	11
Installation of Plasma in the Horizontal Position	12

For customer service call (800) 729-0307 or (708) 865-8870.

Parts List

Description	Qty.	LCC 18	LCC 18-S	LCC 36	LCC 36-S	LCC 36-W
		Part #	Part #	Part #	Part #	Part #
A tube assembly	1	055-1520	055-4520	055-1521	055-4521	055-2521
B ceiling plate	1	580-1042	580-4042	580-1042	580-4042	580-2042
C tilt bracket	1	055-1551	055-4551	055-1551	055-4551	055-2551
D reducer	1	580-1009	580-4009	580-1009	580-4009	580-4009
E #14 x 2.5" wood screw	2	5S1-015-C03	5S1-015-C04	5S1-015-C03	5S1-015-C04	5S1-015-C04
F M5 x 12 mm socket pin screw	4	520-1064	520-2064	520-1064	520-2064	520-2064
G 4 mm security allen wrench	1	560-9646	560-9646	560-9646	560-9646	560-9646
H Alligator® concrete anchor	2	590-0097	590-0097	590-0097	590-0097	590-0097
I 10-32 x 3/8" socket set screw	1	520-1127	500-2018	520-1127	500-2018	500-2018
J hex wrench	1	560-1034	560-1034	560-1034	560-1034	560-1034
K M4 x 10 mm socket pin screw	4	520-1060	520-2060	520-1060	520-2060	520-2060
L M4 x 12 mm serrated washer head socket pin screw	4	510-1079	510-2079	510-1079	510-2079	510-2079
M M4 x 20 mm socket pin screw	4	520-1061	520-2163	520-1061	520-2163	520-2163
N #10-32 x 3/16" slotted set screw	1	520-1187	520-2187	520-1187	520-2187	520-2187
O retaining spacer	4	590-5005	590-5003	590-5005	590-5003	590-5003
P M5 x 10 mm socket pin F-type screw	1	520-1164	520-2031	520-1164	520-2031	520-2031
Q cable tie	3	590-1168	590-1168	590-1168	590-1168	590-1168

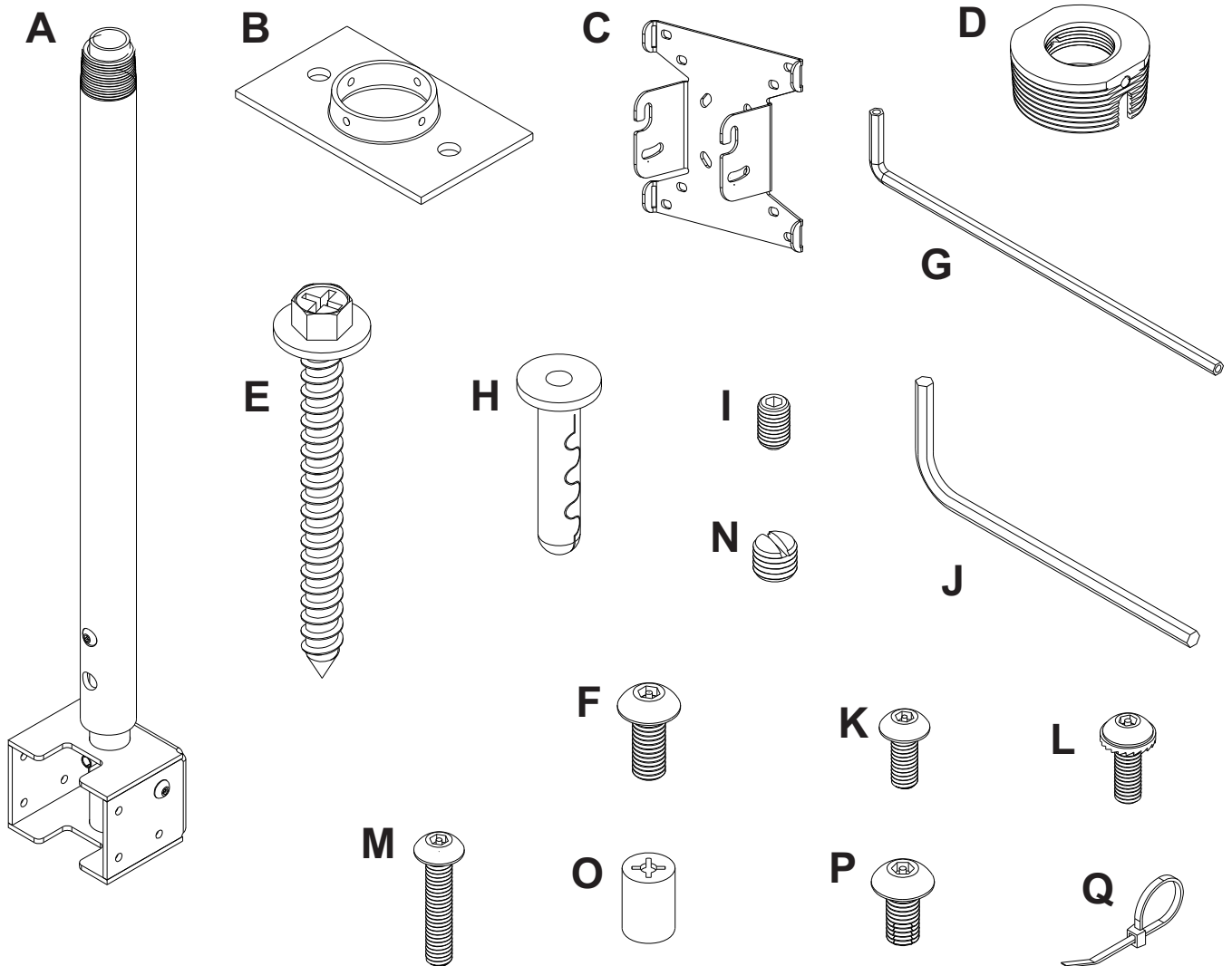

Installation to Wood Joist Finished Ceilings, Exposed Wood Joists, or Wood Beam Ceilings

- 1 Drill two $\frac{5}{32}$ " (4 mm) dia. holes to a minimum depth of 2.5" (64 mm). Attach ceiling plate (B) with two #14 x 2.5" (6 mm x 65 mm) wood screws (E) as shown using $\frac{3}{8}$ " (10 mm) socket wrench. Tighten wood screws (E) so ceiling plate (B) is firmly attached.

⚠ WARNING

- Tighten wood screws so that ceiling plate is firmly attached, but do not overtighten. Overtightening can damage the screws, greatly reducing their holding power.
- Never tighten in excess of 80 in • lb (9 N.M.).
- Make sure that mounting screws are anchored into the center of the joist. The use of an "edge to edge" stud finder is highly recommended.

Skip to step 2 on page 6.

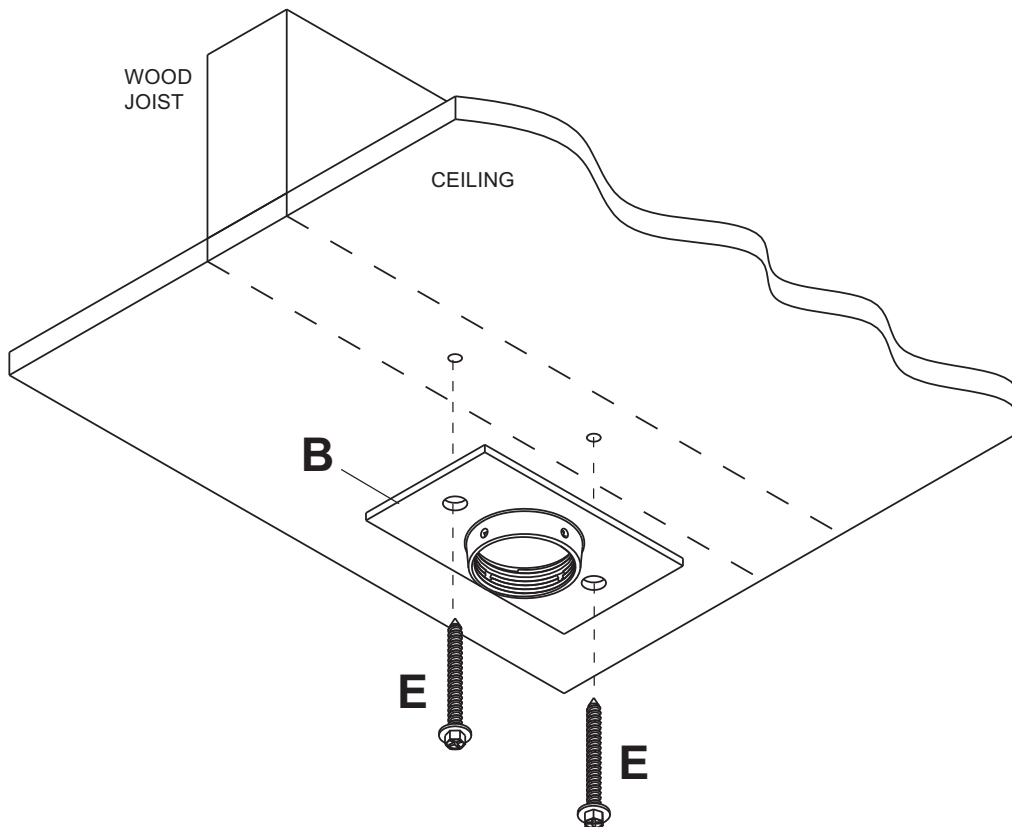

Installation to Concrete Ceilings

- 1 Drill two 1/4" (6 mm) dia. holes to a minimum depth of 2.5" (64 mm). Attach ceiling plate (B) using two concrete anchors (H) and #14 x 2.5" wood screws (E) as shown in **Illustration A** and 1, 2, and 3 (below). Tighten all fasteners.

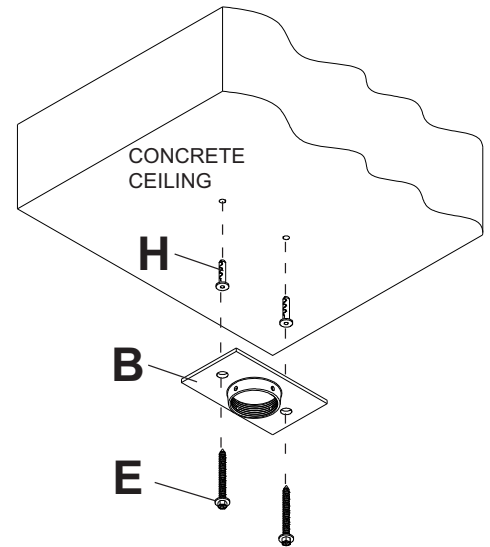

Illustration A

⚠ WARNING

- Tighten wood screws firmly, but do not overtighten. Overtightening can damage the bolt, greatly reducing its holding power.
- Never tighten in excess of 80 in • lb (9 N.M.).

⚠ WARNING

- Concrete anchors are **not** intended for attachment to concrete wall covered with a layer of plaster, drywall, or other finishing material. If mounting to concrete wall covered with plaster/drywall is unavoidable, plaster/drywall (up to 5/8" thick) must be counterbored as shown below. If plaster/drywall is thicker than 5/8", custom fasteners must be supplied by installer (not evaluated by UL).

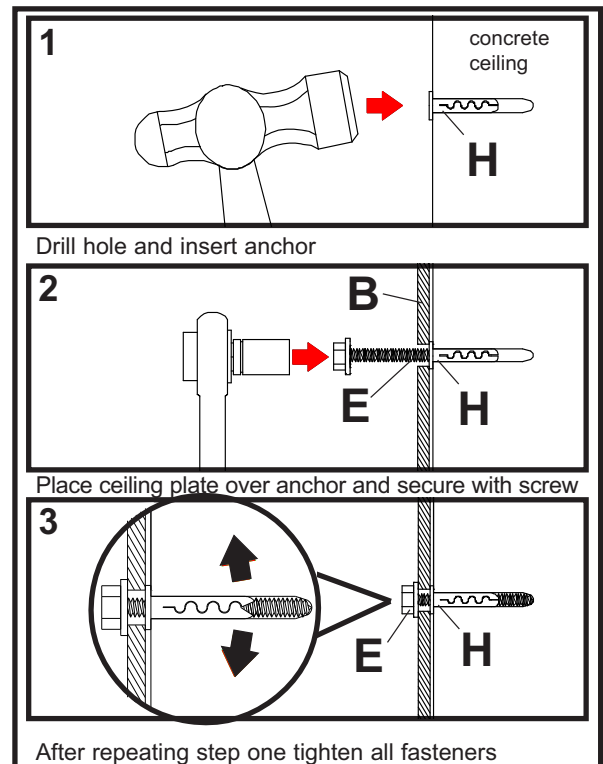
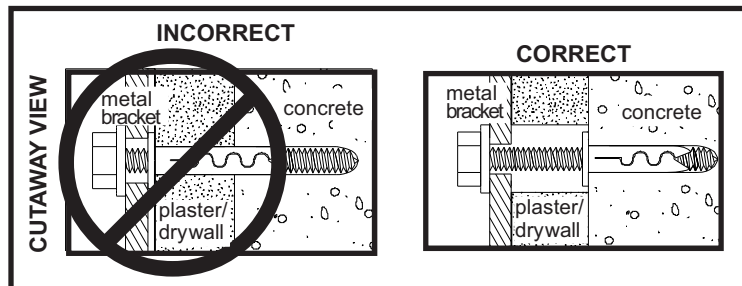

Installing Reducer

2 Thread reducer (D) onto tube assembly (A) until tight. Insert set screw (I) into reducer as shown in figure 2-1. Tighten screw using hex wrench (J). **Note:** Set screw (I) is used to jam against the threads of tube assembly to prevent any excess movement.

To adjust height of tube assembly (A), remove socket pin screw and two lock washers using 4 mm security allen wrench (G) and adjust to desired height as shown in figure 2-2.

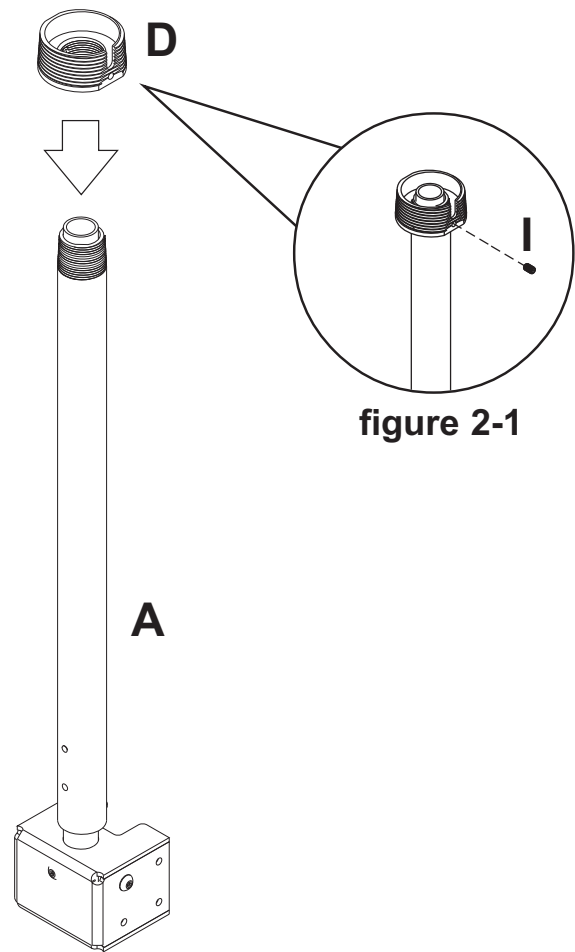

figure 2-1

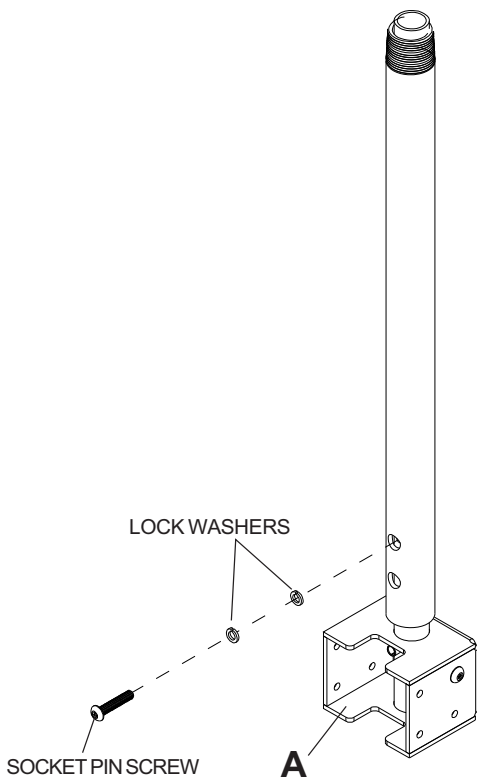
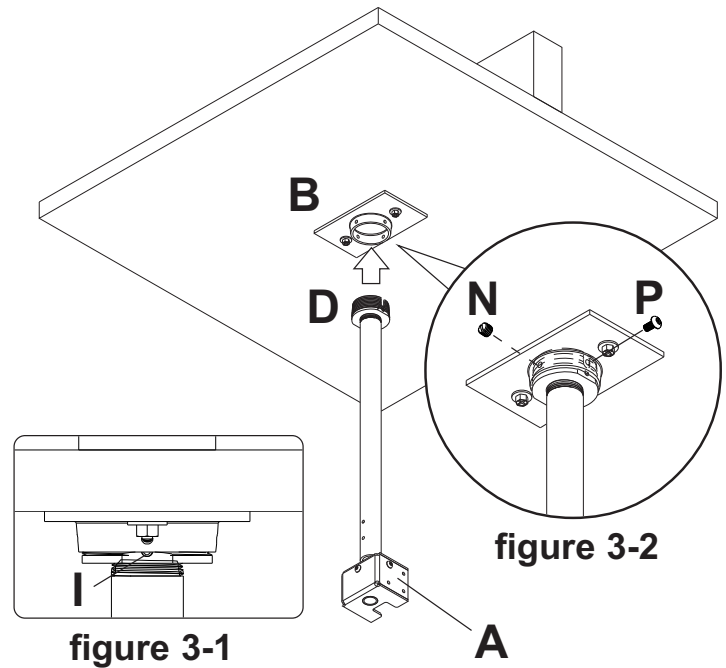

figure 2-2

Flush Mount Installation

- 3** Screw reducer (D) into ceiling plate (B) until notch in reducer is aligned with one of the four holes in ceiling plate and set screw (I) is at least partially covered by ceiling plate as shown in figure 3-1. Secure reducer with one M5 x 10 mm F-type socket pin screw (P) using security allen wrench (G) as shown in figure 3-2. **Note:** Slotted set screw (N) is used to jam against the threads of the reducer to prevent any excess movement of the tube assembly (A). Do not overtighten screw; overtightening screw will damage threads making it difficult to separate the products.

Skip to step 4 on page 10.



Installation to Threaded Rod

Accessory ACC 810 (not evaluated by UL), threaded rod adapter, is required.

- 3** Screw threaded rod adapter (ACC 810) into extension column connector (ACC 109). Align slot in threaded rod adapter with one of the top holes in extension column connector. Insert and tighten one #10-32 x 3/8" socket pin screw provided with extension column connector through extension column connector into slot on threaded rod adapter using 4 mm security allen wrench (G). See figure 3-3.

Align slot in reducer (D) to one of the bottom holes in extension column connector. Insert and tighten one #10-32 x 3/8" socket pin screw provided with extension column connector through extension column connector into slot in reducer. See figure 3-4.

Note: Slotted set screws provided with extension column connector are used to jam against the threads of each connecting joint to prevent any excess movement. Do not overtighten screws; overtightening screws will damage threads making it difficult to separate the products.

Skip to step 4 on page 10.

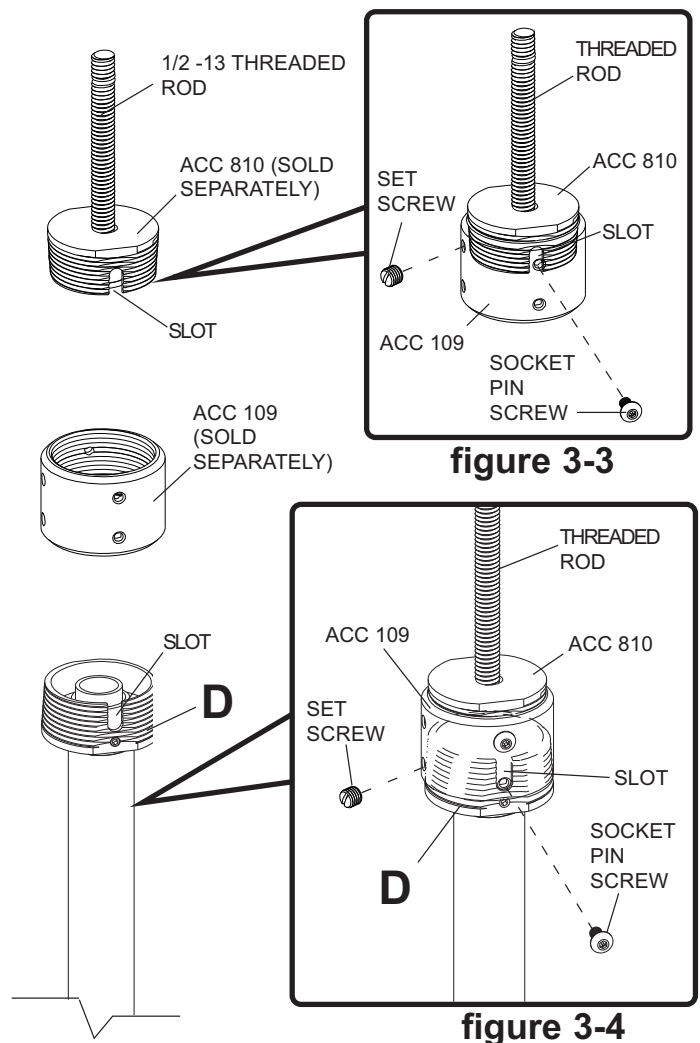

Installation to Extension Column

3 Screw extension column (**EXT or ADJ Series**) to ceiling plate (**B**). Align the notch with one of the four holes in the ceiling plate and secure extension column with a M5 x 10 mm socket pin screw (**P**) using security allen wrench (**G**). See figure 3-5.

Note: Slotted set screw (**N**) is used to jam against the threads of the reducer to prevent any excess movement of the extension column. Do not overtighten screw; overtightening screw will damage threads making it difficult to separate the products.

Screw extension column connector (**ACC 109**) to extension column. Align slot in extension column with one of the top holes in extension column connector. Insert and tighten one #10-32 x 3/8" socket pin screw provided with projector through extension column connector into slot on extension column using security allen wrench (**G**). See figure 3-6.

Screw reducer (**D**) to extension column connector. Align reducer to one of the bottom holes in extension column connector. Insert and tighten one #10-32 x 3/8" socket pin screw provided with connector through extension column connector into slot in reducer using security allen wrench (**G**). See figure 3-7.

Note: Slotted set screws provided with extension column connector are used to jam against the threads of each connecting joint to prevent any excess movement. Do not overtighten screws; overtightening screws will damage threads making it difficult to separate the products.

Skip to step 4 on page 10.

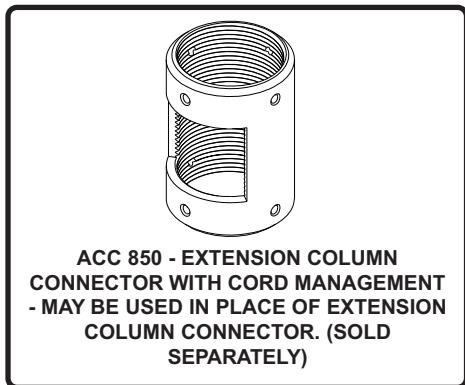
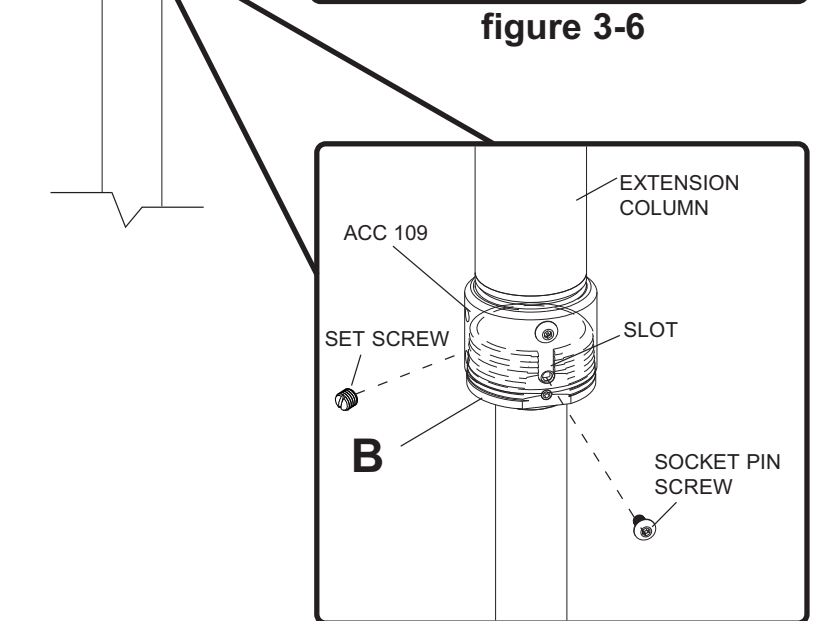
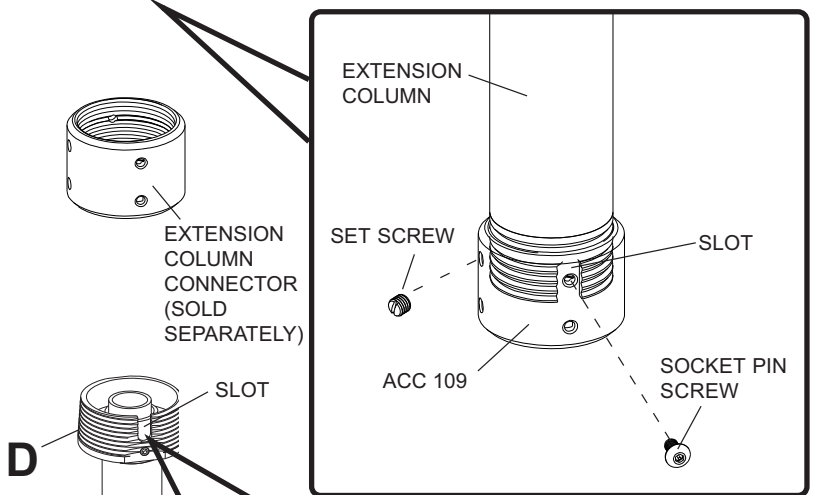
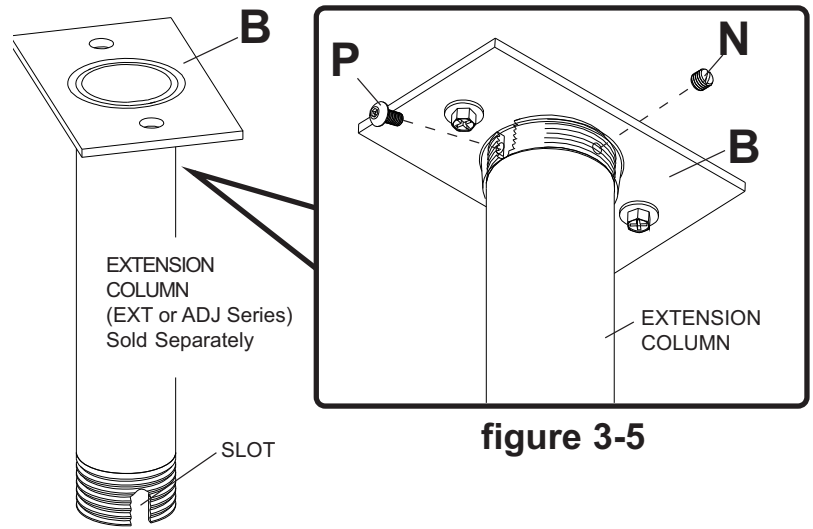

Installation to Lightweight Suspended Ceiling Plate

3 Refer to instruction sheet for lightweight suspended ceiling plate (**CMJ 455**) for attachment of ceiling plate to ceiling.

Screw extension column (**EXT or ADJ Series**) to retaining collar in ceiling tray. Align the notch with one of the four holes in retaining collar and secure extension column with one M5 x 10 mm socket pin screw (**P**) using security allen wrench (**G**). See figure 3-8.

Note: Slotted set screw (**N**) is used to jam against the threads of the reducer to prevent any excess movement of the extension column. Do not overtighten screw; overtightening screw will damage threads making it difficult to separate the products.

Screw extension column connector to extension column. Align slot in extension column with one of the top holes in extension column connector. Insert and tighten one 10-32 x 3/8 socket pin screw provided with connector through extension column connector into slot on extension column using security allen wrench. See figure 3-9.

Screw reducer (**D**) to extension column connector. Align slot in reducer to one of the bottom holes in extension column connector. Insert and tighten one 10-32 x 3/8 socket pin screw provided with connector through extension column connector into slot in reducer using security allen wrench. See figure 3-10.

Note: Slotted set screws provided with extension column connector are used to jam against the threads of each connecting joint to prevent any excess movement. Do not overtighten screws; overtightening screws will damage threads making it difficult to separate the products.

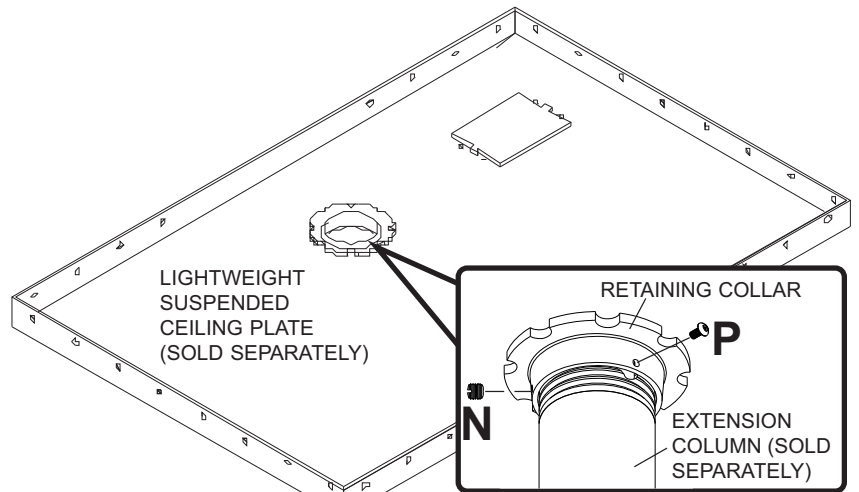
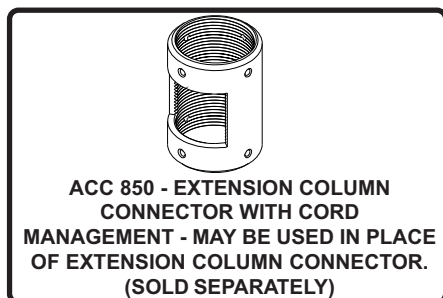

figure 3-8

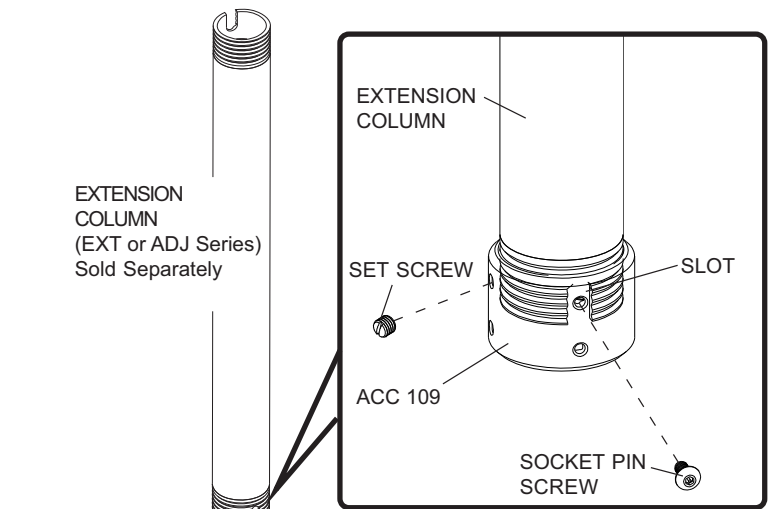

figure 3-9

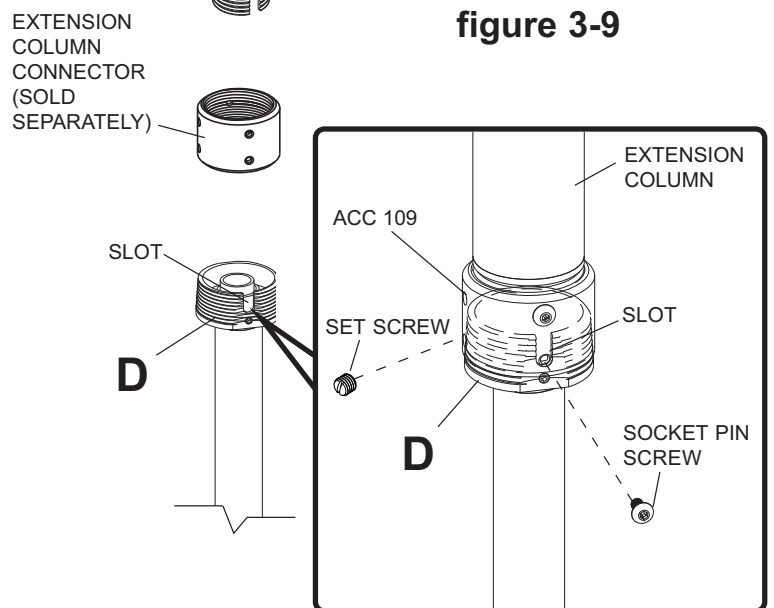

figure 3-10

Attaching Tilt Bracket to LCD Screen

4 **Note:** This product is designed to accommodate screens with VESA® compliant hole patterns. For safe mounting, please make sure that mounting screws turn at least three complete turns in the screen inserts.

FOR VESA 75 MOUNTING PATTERN:

1) Choose hole pattern indicated below. 2) Attach tilt bracket (**C**) to back of screen using four M4 x 10 mm screws (**K**) as indicated below. 3) If hole pattern is in a pocket, attach tilt bracket to back of screen using four M4 x 20 mm screws (**M**) and four retaining spacers (**O**) as indicated below. Tighten all security screws with security allen wrench (**G**).

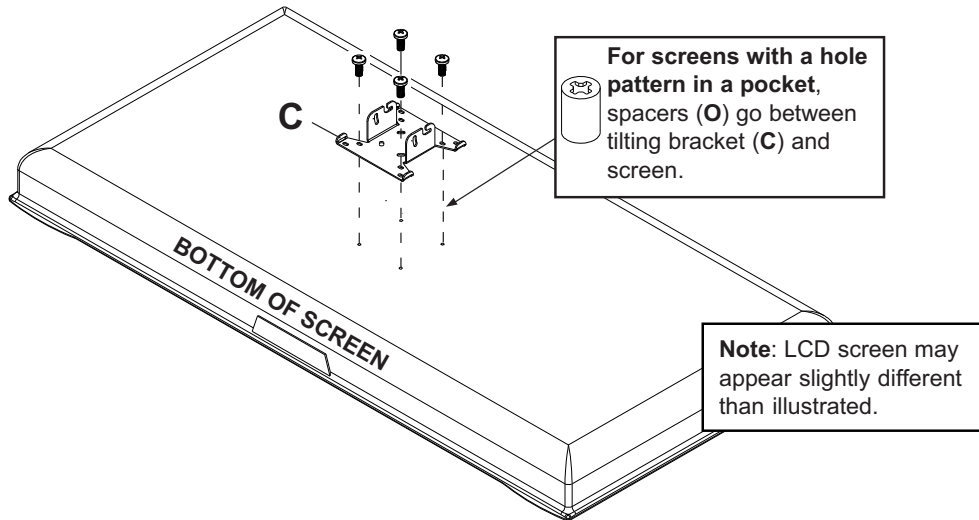

FOR VESA 100 MOUNTING PATTERN:

1) Choose hole pattern indicated below. 2) Attach tilt bracket (**C**) to back of screen using four M4 x 10 mm screws (**K**) as indicated below. Tighten all security screws with security allen wrench (**G**).

Note: If installing LCD screen model Sharp® LC-13E1U, LC-15E1U, LC-20E1U, or if you don't get three complete turns in the screen inserts, use four M4 x 12 mm screws (**L**) instead of four M4 x 10 mm screws (**K**).

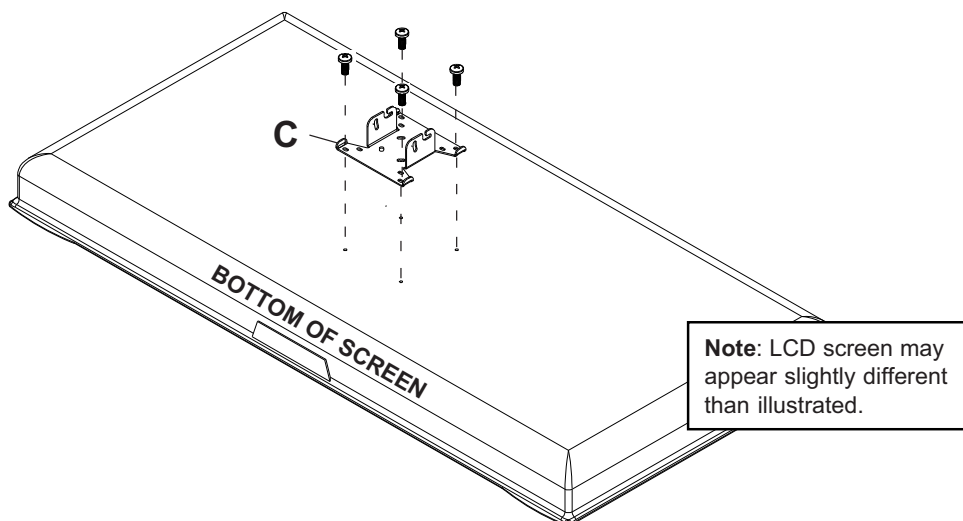

Installation of Screen in the Vertical Position

- 5** Insert two M5 x 12 mm screws (F) into column bracket of tube assembly (A) (see figure 5-1). Leave approximately 3/16" of thread exposed (see figure 5.2).

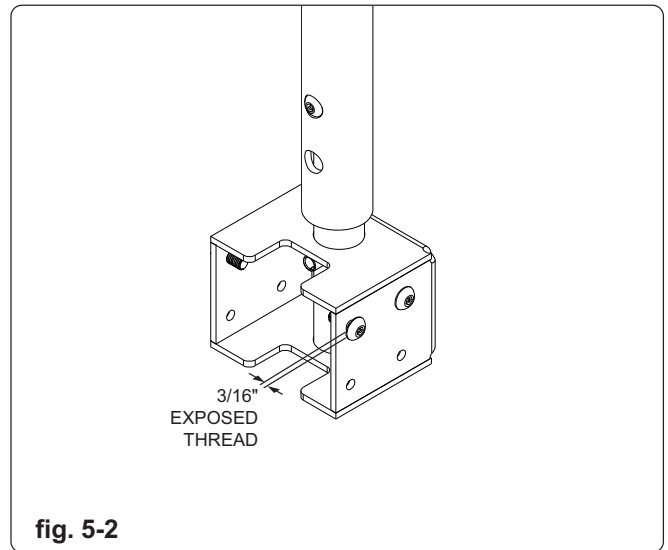
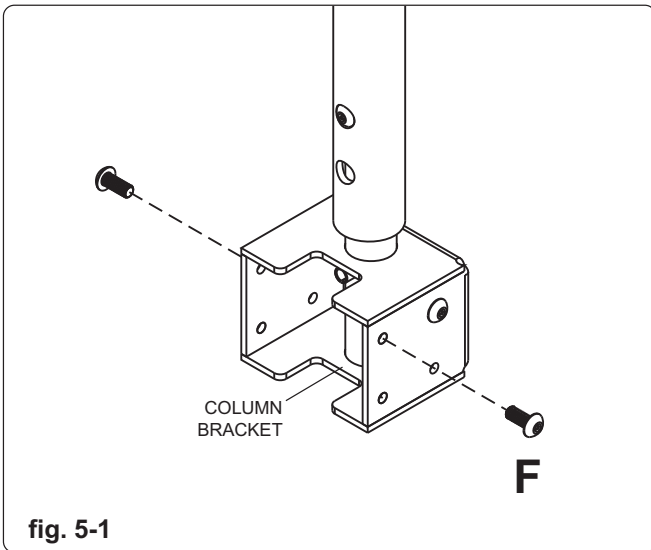

- 6** Hook tilt bracket (C) onto column bracket (see figure 6-1). Secure with two M5 screws (F) (see figure 6-2). Adjust tilt (20° forward and 5° back) and swivel to desired position. Tighten all screws using security allen wrench (G).
Note: Cable ties (Q) are provided for optional cord management along tube.

⚠ WARNING

- Always use an assistant or mechanical lifting equipment to safely lift and position the LCD screen.

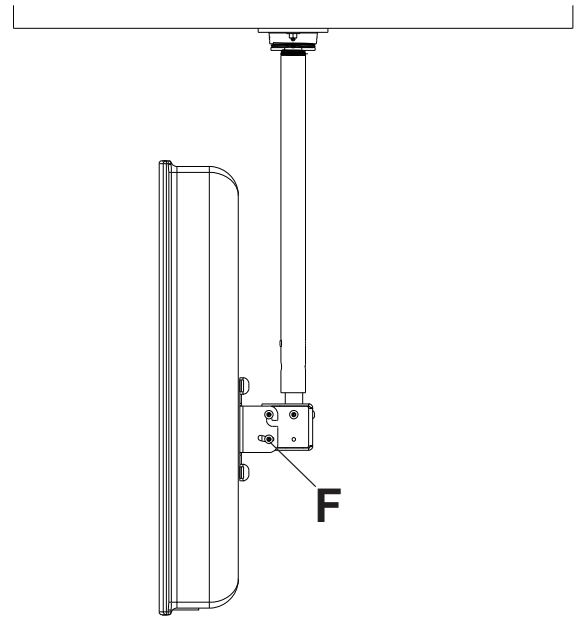
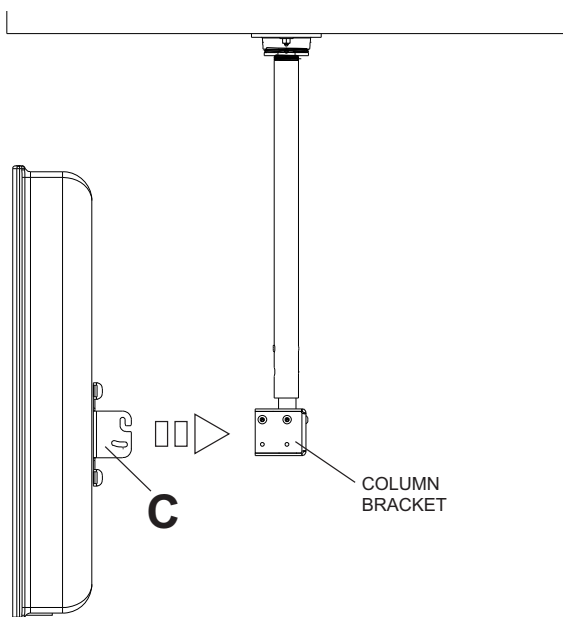

Installation of Screen in the Horizontal Position

- 5** Insert two M5 x 12 mm screws (F) into column bracket of tube assembly (A) (see figure 5-1). Leave approximately 3/16" of thread exposed (see figure 5-2).

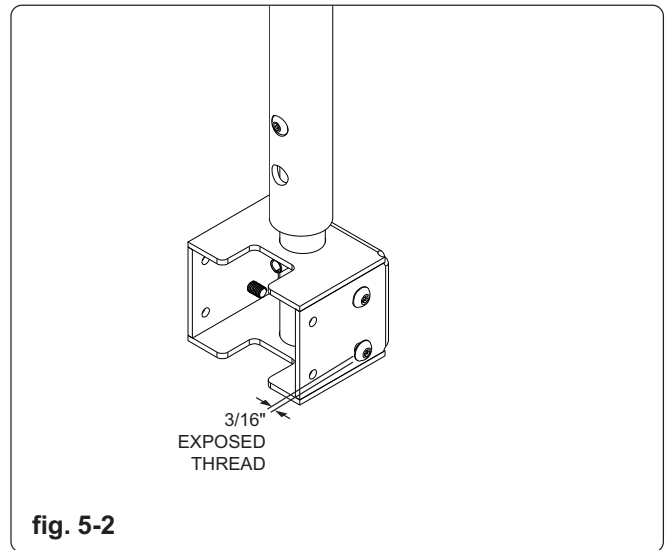
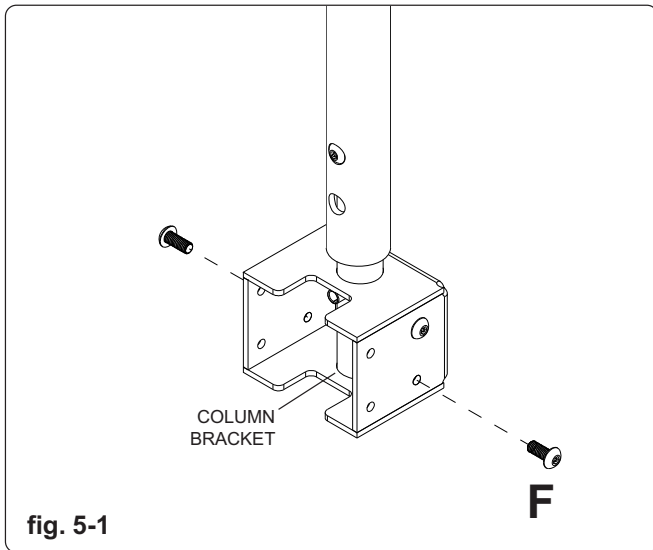

- 6** Hook tilt bracket (C) onto column bracket (see figure 6-1). Secure with two M5 screws (F) (see figure 6-2). Adjust tilt (20° forward and 5° back) and swivel to desired position. Tighten all screws using security allen wrench (G).
Note: Cable ties (Q) are provided for optional cord management along tube.

⚠ WARNING

- Always use an assistant or mechanical lifting equipment to safely lift and position the LCD screen.

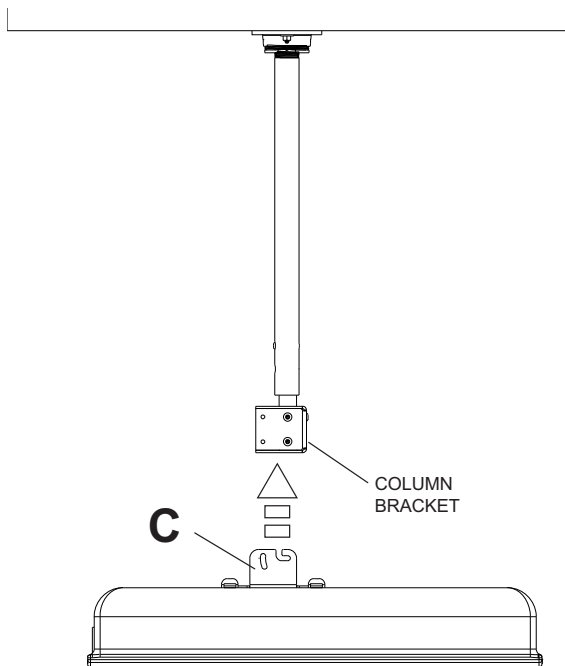

fig. 6-1

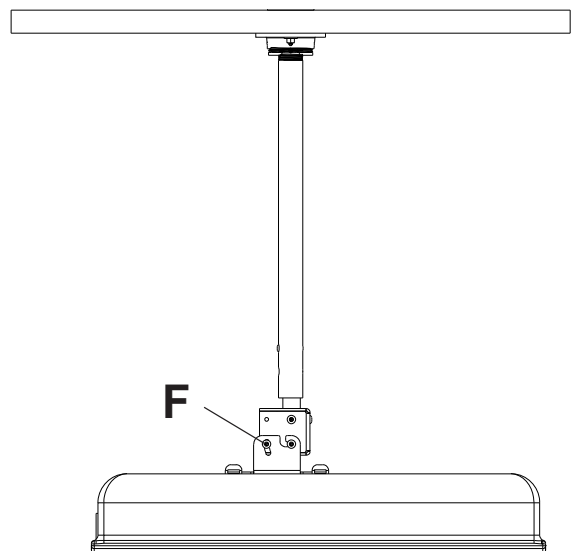

fig. 6-2